VOLUME 6 ROAD GEOMETRY
SECTION 2 JUNCTIONS

PART 3

TD 50/04

THE GEOMETRIC LAYOUT OF SIGNAL-CONTROLLED JUNCTIONS AND SIGNALISED ROUNDABOUTS

SUMMARY

This document sets out the design standards, methodology and good design practice for the geometric layout of signal-controlled junctions and signalised roundabouts for trunk roads. Measures to ensure safe operation for all road users are described. TD 50/04 supersedes TD 50/99.

INSTRUCTIONS FOR USE

This Standard now contains expanded advice at paragraph 2.10 for Junction Intervisibility Zones for junctions with Advance Stop-Lines for cyclists.

1. Remove existing contents page for Volume 6 and insert new contents pages for Volume 6 dated November 2004.
2. Remove TD 50/99 from Volume 6, Section and archive as necessary.
3. Insert TD 50/04 into Volume 6, Section 2, Part 3.
4. Please archive this sheet as appropriate.

Note: A quarterly index with a full set of Volume Contents Pages is available separately from The Stationery Office Ltd.



THE HIGHWAYS AGENCY



SCOTTISH EXECUTIVE



Llywodraeth Cynulliad Cymru
Welsh Assembly Government

**WELSH ASSEMBLY GOVERNMENT
LLYWODRAETH CYNULLIAD CYMRU**



**THE DEPARTMENT FOR REGIONAL DEVELOPMENT
NORTHERN IRELAND**

The Geometric Layout of Signal- Controlled Junctions and Signalised Roundabouts

Summary: This document sets out the design standards, methodology and good design practice for the geometric layout of signal-controlled junctions and signalised roundabouts for trunk roads. Measures to ensure safe operation for all road users are described. TD 50/04 supersedes TD 50/99.

REGISTRATION OF AMENDMENTS

Amend No	Page No	Signature & Date of incorporation of amendments	Amend No	Page No	Signature & Date of incorporation of amendments

REGISTRATION OF AMENDMENTS

Amend No	Page No	Signature & Date of incorporation of amendments	Amend No	Page No	Signature & Date of incorporation of amendments

VOLUME 6 ROAD GEOMETRY
SECTION 2 JUNCTIONS

PART 3

TD 50/04

**THE GEOMETRIC LAYOUT OF SIGNAL-
CONTROLLED JUNCTIONS AND
SIGNALISED ROUNDABOUTS**

Contents

Chapter

1. Introduction
2. Geometric Design Features
3. Safety
4. Road Users' Specific Requirements
5. Junction Arrangements and Operation
6. Signalised Roundabouts
7. References
8. Enquiries

Annex 1 Terms and Definitions used in Signal
Control

1. INTRODUCTION

General

1.1 This standard identifies those aspects of signal control which have an effect on geometric layout design, and which should be considered throughout the design process. Advice on the method of installation, control and signal display sequences are contained within **Design for Manual Roads and Bridges, Volume 8, Section 1** (ie **DMRB 8.1**). Close co-operation is necessary where a different engineering team or discipline is responsible for separate aspects of design, eg geometry, signal control and street lighting. This is particularly relevant in the early stages of design. To assist this process, terms and definitions more frequently used in signal control are provided in **Annex 1**.

1.2 This document sets out standards, methodology and good practice for the design of geometric layouts for signal-controlled junctions and signalised roundabouts where the 85th percentile speed on the approach roads are below 104kph (65mph). Traffic signals are not recommended where this approach speed is exceeded [See **TA 12 (DMRB 8.1.1)**].

1.3 This standard shall apply to all new junctions which are signal-controlled, signalised roundabouts and to all existing uncontrolled priority junctions which are modified or improved to operate with signal control.

1.4 **Local Transport Notes (LTN)** identified in the **Department for Transport (DfT)** publication list review the techniques available and recommend factors to be considered when introducing traffic signal control at roundabouts. The geometric layout of signalised roundabouts should be designed in accordance with **TD 16 (DMRB 6.2.3)**, however additional geometric design guidance on the application of traffic signals to roundabouts is provided in **Chapter 6** of this document.

Existing Signal-Controlled Junctions and Junctions Converted to Signal Control

1.5 At existing signal-controlled junctions this standard should be considered as advice which is commended to designers when assessing possible alterations or improvements to the performance of the junction.

1.6 Where signal control is being installed as a safety measure at an existing priority junction with sub-standard junction visibility or where existing signal-controlled junctions are being modified or improved, constraints are often imposed upon the design by the existing road geometry, buildings, availability of land or the cost of moving statutory undertakers' apparatus. Under these conditions, design standards contained in this document should be incorporated where possible to improve the overall safety for all road users and the junction design and signalling arrangements should be developed to maximise the junction intervisibility. The procedure for approval of non-compliant elements of design is outlined in **Paragraph 1.18** (Departures from Standard).

1.7 The geometric layout indicated in **Figure 1/1** is intended to illustrate a situation where the physical constraints imposed by buildings (and statutory undertakers' equipment) may affect the overall geometric layout.

Principal Objectives

1.8 Introducing signal control at a junction, including measures to provide the maximum degree of safety and convenience for all road users, can enhance efficiency by reducing congestion and conflict between different vehicle movements, within the available road space. The use of signal control should therefore be considered as an option at the scheme assessment stage for new junctions and the improvement of existing junctions. Guidance on the selection of the most appropriate junction option is given in **TA 30 (DMRB 5.1.4)**.

1.9 Signal control may also be used in association with (or to implement) other strategies such as:

- a. augmenting or altering a natural or designated route priority;
- b. providing a safe, convenient environment for pedestrians and cyclists;
- c. giving priority to buses and coaches;
- d. area traffic control;
- e. light rapid transit systems (see **HM Railway Inspectorate Technical Note (RTN 4)**).

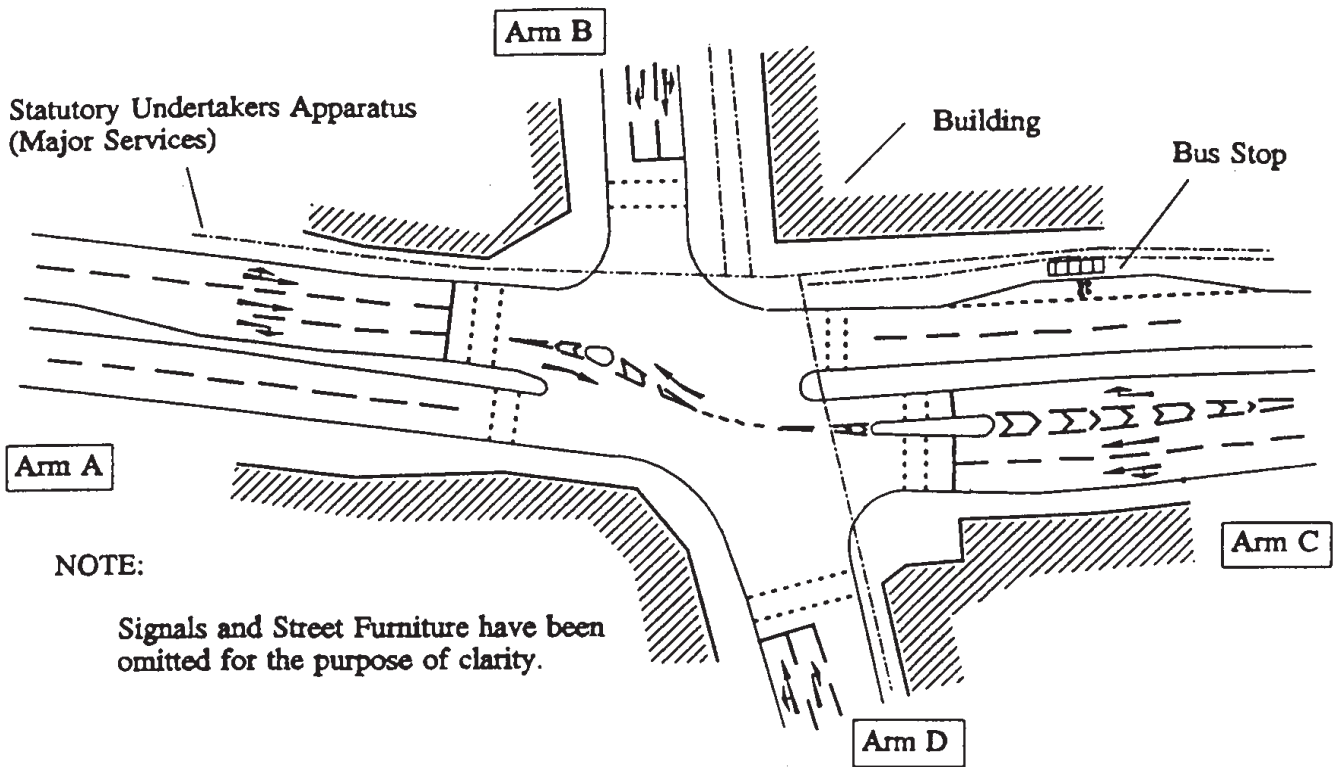

Figure 1/1: Example of Existing Signal-Controlled Junction Subject to Design Constraints

Implementation

1.10 This Standard shall be used forthwith on all schemes for the construction, improvement and maintenance of trunk roads currently being prepared provided that, in the opinion of the Overseeing Organisation, this will not result in significant additional expense or delay progress. Design Organisations should confirm its application to particular schemes with the Overseeing Organisation.

1.11 It is important to identify the full requirements of the scheme at the preliminary design stage, before acquiring land (eg if pedestrian crossing routes are not identified it could be difficult to include them later without either obtaining additional land or compromising the layout).

1.12 Design of a signal-controlled junction is an iterative process involving the assessment of traffic performance of draft layouts followed by appropriate modifications to the geometric layout to finally obtain the optimum solution. There is a limit to what may be achieved in terms of increased capacity by, for example, widening junctions to provide additional lanes, introducing traffic islands or improving turning radii. A balance normally needs to be sought.

Scope

1.13 This standard sets out the specific requirements which should be met for signal-controlled junctions and signalised roundabouts on trunk roads where the 85th percentile speed on the approach to the junction does not exceed 104kph (65mph) on any arm.

1.14 Design features which relate specifically to pedestrians, cyclists, equestrians and buses are contained in **Chapter 4** of this document.

1.15 The geometric features and layout should be designed to accommodate the positioning of signalling equipment (including mast-arms where appropriate), pedestrian facilities and equipment, signs, illuminated bollards, guardrails, and stop lines. It is also necessary to consider maintenance requirements and use of the junction under police control when carrying out the geometric design.

1.16 In the various figures, the junction arms are referenced clockwise (commencing at the major road), so that the order is major-minor-major. Basic primary and secondary signals, pedestrian signals and push buttons are generally indicated in the figures, however advice on the type, aspect and symbol for particular circumstances is contained in **DMRB 8.1**. Other design features and turning restrictions are included to illustrate their application. The inclusion or exclusion of design features is not intended to suggest applicability to particular junction arrangements.

Large Goods Vehicles

1.19 The term **Large Goods Vehicles** is used in this document to identify those vehicles (defined as over 3.5 tons gross weight) classified as LGV's for licensing purposes in accordance with European harmonisation of terminology.

Mandatory Sections

1.17 Sections of this document which form part of the standards which the Overseeing Organisation requires in design are highlighted by being contained in boxes. These are the sections with which the Design Organisation must comply or must have agreed a suitable departure from standard with the relevant Overseeing Organisation. The remainder of the document contains advice and enlargement which is commended to designers for their consideration.

Departures from Standard

1.18 In those situations where, for reasons of significant environmental impact or high cost, a designer considers that a mandatory requirement of this Standard may be inappropriate, the design organisation shall apply to the relevant Overseeing Organisation for approval to adopt a Departure from Standard. Design Organisations faced by such situations and wishing to consider pursuing this course shall discuss any such option at an early stage in design with the relevant Overseeing Organisation. Proposals to adopt Departures from Standard must be submitted by the Design Organisation to the Overseeing Organisation and formal approval received BEFORE incorporation into a design layout.

2. GEOMETRIC DESIGN FEATURES

General

2.1 This chapter outlines the geometric design features to be considered in the design of signal-controlled junctions. Many of the features are considered separately, and designers should adopt a systematic approach to achieve a satisfactory design incorporating all appropriate geometric design features.

Design Speed

2.2 Some design standards are dependent on the approach speed of vehicles and reference should be made to **TD 9 (DMRB 6.1.1)** to determine appropriate design speeds for each entry arm. Where these design speed related standards cannot be achieved then traffic management measures should be introduced to reduce the approach speed to an appropriate value, for the available Stopping Sight Distance (**SSD**).

2.3 **TA 22 (DMRB 5.1.4)** provides guidance for determining speed limits, and design speeds based upon the 85th percentile approach speed of traffic.

2.4 Drivers travelling at even moderately high speeds on roads where signal control is installed can find themselves with a difficult decision to make when green changes to amber and drivers are often faced with a choice between attempting to brake to a halt at the stop-line, or continuing at the same speed through the junction and clearing it safely. Because of the increased braking distances required at high speeds, drivers need adequate warning that they are approaching a signal-controlled junction. The use of **High Friction Surfacing** should also be considered [See paragraph 2.57].

2.5 High approach speeds can also result in those drivers making right turn manoeuvres misjudging the lengths of gaps in opposing traffic, which in turn increases the risk of accidents. The resulting indecision in these circumstances may put drivers and others at risk and designers should consider measures to mitigate these effects [See **TA 12 (DMRB 8.1)**].

Visibility on the Approach to Junctions

2.6 The stopping sight distance on the immediate approach to the junction [See paragraph 1.26, **TD 9 (DMRB 6.1.1)**] shall be in accordance with the standards contained in **TD 9 (DMRB 6.1.1)** and Relaxations below Desirable Minimum Stopping Sight Distance (**DMSSD**) shall not be permitted on the immediate approaches to the junction.

2.7 Each traffic lane shall have clear vision of at least one primary signal associated with its particular movement, from a distance equivalent to the **DMSSD**. The visibility envelope [See **Figure 3, TD 9 (DMRB 6.1.1)**] shall be increased to include the height of the signal head as indicated in **Figure 2/1**.

2.8 Once the control strategy for the junction has been established and queue lengths determined, further checks should be undertaken to ensure that the **DMSSD** is provided to the back of the queue. Where the **DMSSD** cannot be achieved measures should be taken to reduce queue lengths and provide signs warning drivers of stationary traffic ahead.

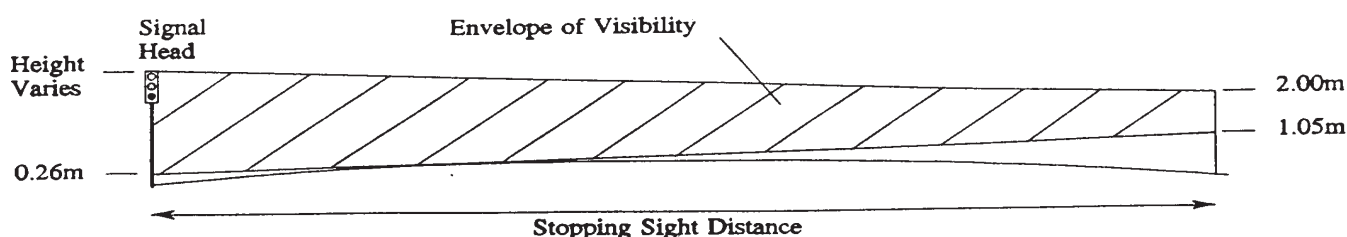

Figure 2/1: Visibility Requirements on Approach to Junction

2.9 The visibility requirements for pedestrians using crossings are contained in **Chapter 4** of this document.

Junction Intervisibility Zone

2.10 The junction intervisibility zone is the area identified for the purpose of assessing visibility within the junction between drivers at each stop-line, or between drivers and pedestrians and facilitates identification of measures to mitigate the effect of obstructions. The junction intervisibility zone is defined as the area bounded by measurements from a distance of 2.5m behind the stop-line extending across the full carriageway width for each arm as indicated in **Figure 2/2**. If an Advance Stop-Line is provided [See **Figure 4/3**] the intervisibility zone is measured from a point 2.5m behind the cyclists' stop-line. This is because the cycle reservoir behind the Advance Stop-Line does not create any physical impediment to intervisibility.

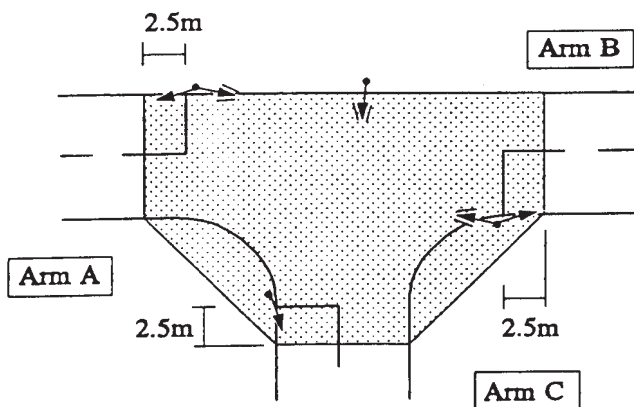

Figure 2/2: Junction Intervisibility Zone (without crossings)

2.11 To ensure that drivers of all vehicles on each entry lane are able to see the full extent of the pedestrian crossing (and its approach) the junction intervisibility zone should be extended, where necessary, to include the full width of the strip of tactile paving laid parallel to the edge of carriageway, as indicated on Arm A of **Figure 2/3**.

2.12 **Chapter 5** provides further examples to illustrate the junction intervisibility zones for a number of junction arrangements. At a staggered junction the layout will result in two independent junction intervisibility zones [See **Figures 5/6 and 5/7**], however as the stagger length reduces the junction

intervisibility zones will overlap, forming a single junction intervisibility zone.

2.13 Where a staggered pedestrian crossing is provided [See **Figure 5/3**], the section of the crossing immediately adjacent to the junction should be included in the junction intervisibility zone. The junction intervisibility zone need not be extended to include a displaced pedestrian crossing which is remote from the main junction [See **Figure 5/1**].

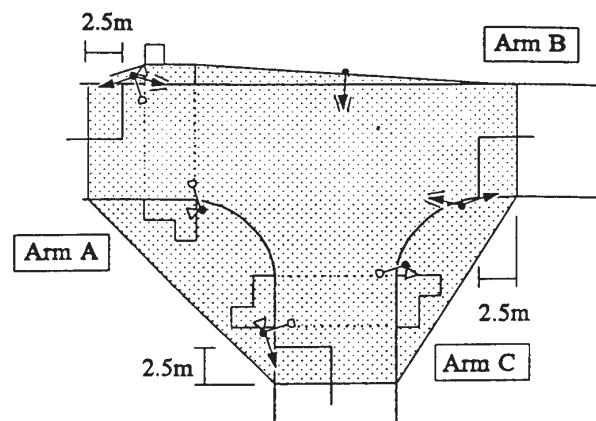

Figure 2/3: Junction Intervisibility Zone (with crossings)

Junction Intervisibility

2.14 Due to the control imposed on drivers, the visibility requirements measured from the stop-line for signal-controlled junctions are not as onerous as those for major/minor priority junctions [See **paragraph 7.6, TD 42 (DMRB 6.2.6)**]. It is essential however to provide adequate intervisibility for drivers at each stop-line, and between drivers at a stop-line and each of its associated exit lanes (and pedestrian crossings), to permit manoeuvres to be completed safely once the driver has entered the junction intervisibility zone. **Paragraphs 1.5 to 1.7** provide advice regarding installation of signal control at existing priority junctions.

2.15 Adequate intervisibility ensures a level of safety for all road users of the junction. Designers should aim to achieve the greatest level of intervisibility for both drivers and pedestrians within the junction intervisibility zone and it is important to consider the

combined effect of building lines and pedestrian crossing locations when checking intervisibility and identifying locations for pedestrian crossings.

2.16 At new signalised junctions [See paragraph 1.3] major obstructions to intervisibility within the junction intervisibility zone, such as that caused by buildings should be avoided. Under these conditions each obstruction to visibility shall be considered as a **Departure from Standard** and measures shall be taken to mitigate the effects on intervisibility.

2.17 **Figure 2/4** illustrates the reduction in intervisibility for a vehicle at the stop-line on the left turn entry lane (Arm C) and the exit lane and pedestrian crossing (Arm D), caused by a major obstruction. **Figure 2/5** illustrates how the intervisibility between Arm C and Arm D can be mitigated, by moving the stop-line forward and providing an in-line [See Paragraph 4.6] pedestrian crossing on Arm C. When adjusting the position of the stop-line and pedestrian crossing, the effect of the position of the pedestrian refuge on vehicle swept paths should be checked, and its effect on pedestrians, particularly visually impaired people, should be considered.

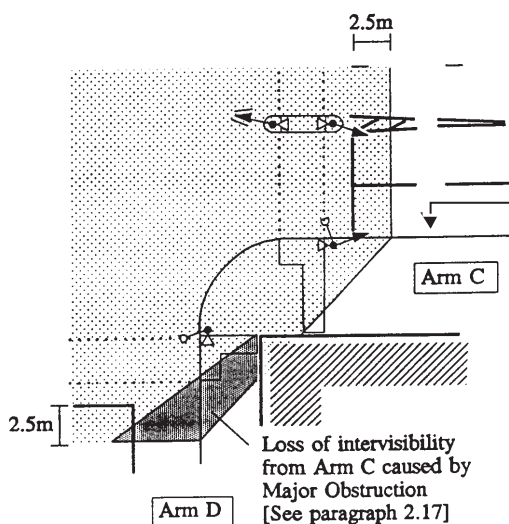

Figure 2/4: Major Obstruction to Intervisibility

2.18 Minor obstructions to visibility caused by slim projections such as lighting columns, sign supports, signal posts, controller cabinet and guardrails placed within the junction intervisibility zone may be unavoidable in the optimum design. When placing signs, street furniture and planting, consideration should be given to ensure that their obstructive effect is minimised. Minor obstructions are not considered as either departures from or relaxations within standard.

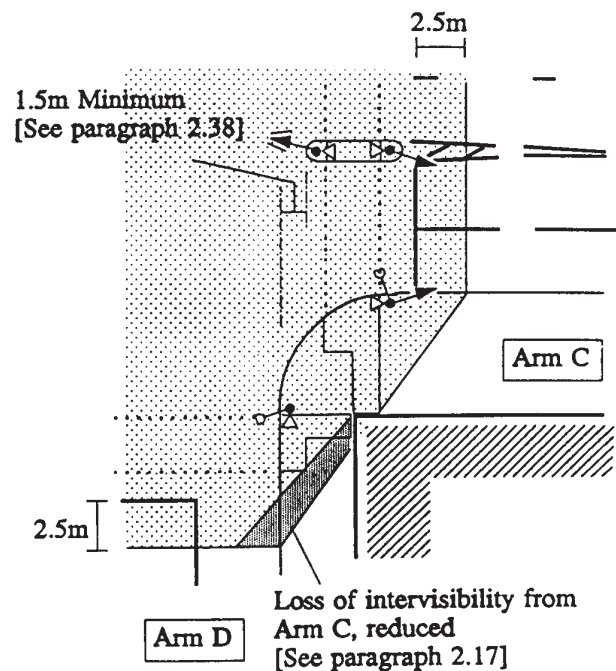

Figure 2/5: Mitigation of Major Obstruction to Intervisibility

Corner Radii

2.19 Where no special provision is to be made for large goods vehicles it is recommended that the minimum radius should be 6m in urban areas and 10m in rural areas.

2.20 Where provision is to be made for large goods vehicles **Table 2/1** and **Figures 2/6** and **2/7** indicate the minimum standards for circular corner radii and tapers.

Variable	Urban	Rural
R	10m	15m
T	5	10
A	30m	25m
B	30m	25m

Table 2/1: Corner Radii and Tapers

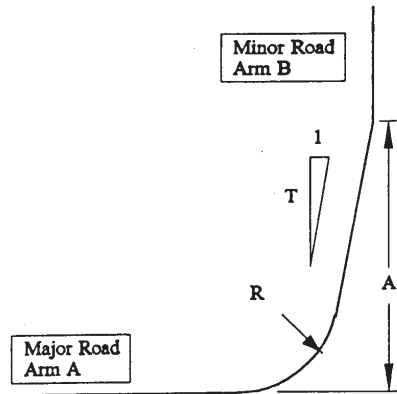

Figure 2/6: Entry to Minor Road

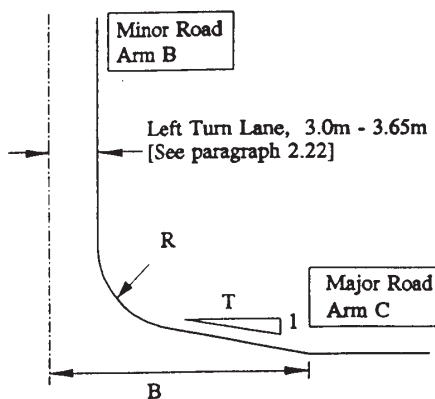

Figure 2/7: Entry to Major Road

2.21 Where large goods vehicles comprise a significant proportion of the turning movements, use of the compound curve shown in **Figure 7/3, TD 42 (DMRB 6.2.6)** is recommended.

Carriageway Widths

2.22 Where new junctions are being designed as signal-controlled junctions, entry lane widths should be between 3m and 3.65m, unless there are specific reasons to justify the use of narrower or wider lane widths. Where a significant number of cyclists are anticipated a minimum width of 4.0m should be provided between physical islands, while consideration should also be given to the possibility of introducing specific measures for cyclists as set out in **Chapter 4**.

2.23 Where an existing signal-controlled junction or an uncontrolled junction is being improved or modified and available road space is restricted, then the permitted lane widths for straight ahead entry lanes may be reduced to 2.5m providing that the 85th percentile approach speed does not exceed 56kph (35mph), and the reduced width enables a necessary extra lane to be provided on multi-lane entries. In exceptional circumstances lane widths may be reduced to 2.25m where it is not necessary to make particular provision for large goods vehicles.

2.24 Road markings should be provided to channelise traffic and hatch out areas of carriageway which would otherwise result in excessively wide lanes, or which could cause driver confusion [See **Figures 5/1 to 5/3**].

Entry Lanes

2.25 Where land is available, junction capacity can be increased by widening the road in the vicinity of the junction to provide dedicated left or right turn entry lanes. Vehicles in the dedicated turning lanes will often move independently to those in other lanes and sufficient lane width and length should be provided to allow this. A minimum width of 3m is recommended for the dedicated turning lanes developed with tapers of 1 in 5, as indicated in **Figures 2/8 and 2/9**.

2.26 On single carriageway roads, right turn entry lanes may be accommodated by the provision of a ghost island. The ghost island should be designed to provide adequate storage length for right turn vehicles and should normally be developed symmetrically about the centreline of the road with a taper of 1 in 10, as indicated in **Figure 2/10**.

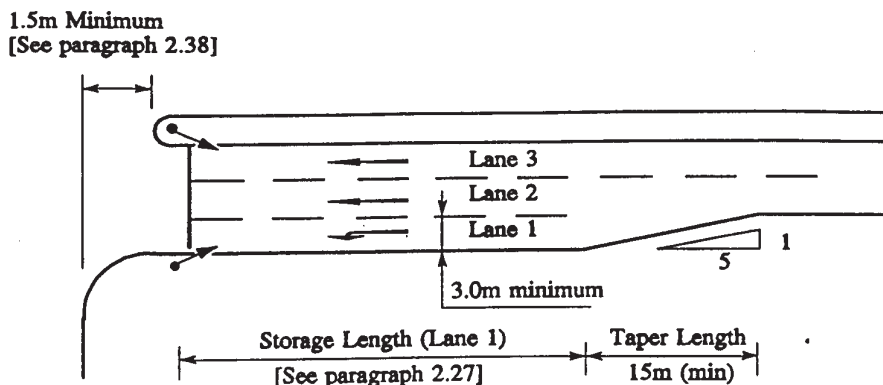

Figure 2/8: Left-Turn Approach Lane

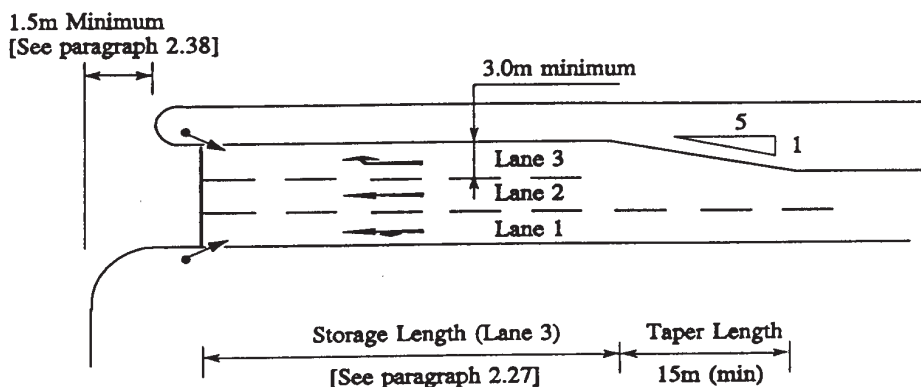

Figure 2/9: Right-Turn Approach Lane

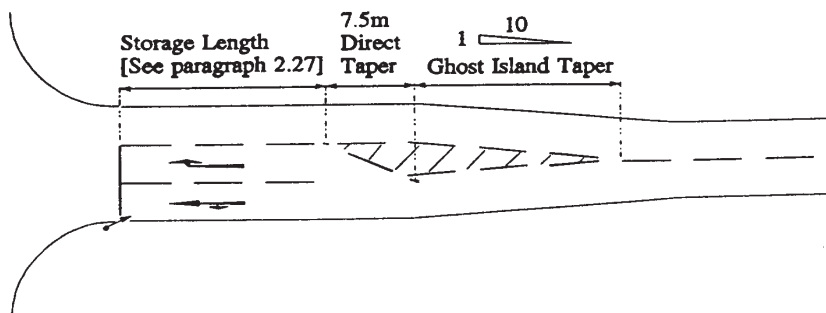

Figure 2/10: Ghost Island Layout

Storage Length

- 2.27 The storage length is the length of the entry lane (full width), measured from the stop-line, over which vehicles can queue without causing obstruction to, or being obstructed by, vehicles in the adjacent lane.
- 2.28 The storage length of the left and right turn entry lanes should be designed to meet the capacity requirements of the junction. To avoid turning traffic blocking the adjacent lane it should be of sufficient length to accommodate the longest queue of stopped traffic. Similarly traffic may be prevented from entering the left or right turn lane where there is a high proportion of straight ahead traffic queuing in the adjacent lane. The storage length may be extended to enable traffic to enter the turning lane unobstructed.
- 2.29 Where displaced [See **Figure 5/1**] or remote pedestrian crossings are installed, designers should ensure that adequate storage length is provided to avoid traffic queuing back into the junction.
- 2.30 The term reservoir length refers to the length required for vehicles queuing, between the staggered arms, at staggered junctions. The requirements for stagger distances and reservoir lengths are contained in **Chapter 5**.

Lane Continuity

- 2.31 The number of straight ahead entry and exit lanes for a traffic stream should be balanced in order to reduce conflict caused by traffic merging or diverging within the junction intervisibility zone. Where it is necessary to reduce the number of lanes on the exit arm this should be carried out beyond the junction intervisibility zone, over a distance of 100 metres for a single lane reduction, measured from the limit of the junction intervisibility zone, as indicated in **Figure 2/11**. The lane reduction may be carried out on either the nearside or offside dependent upon traffic conditions.
 - 2.32 The use of lane markings within the junction intervisibility zone, as illustrated in **Figure 2/11**, may also be beneficial to direct traffic streams and reduce conflict where entry and exit lane widths vary or the alignment through the junction is not a direct path.
- ### Carriageway Widths Around Curves
- 2.33 Where provision is to be made for large goods vehicles, buses and coaches, carriageways or lanes may require widening around curves in accordance with the standards contained in **TD 42 (DMRB 6.2.6) paragraphs 7.25 to 7.27**.

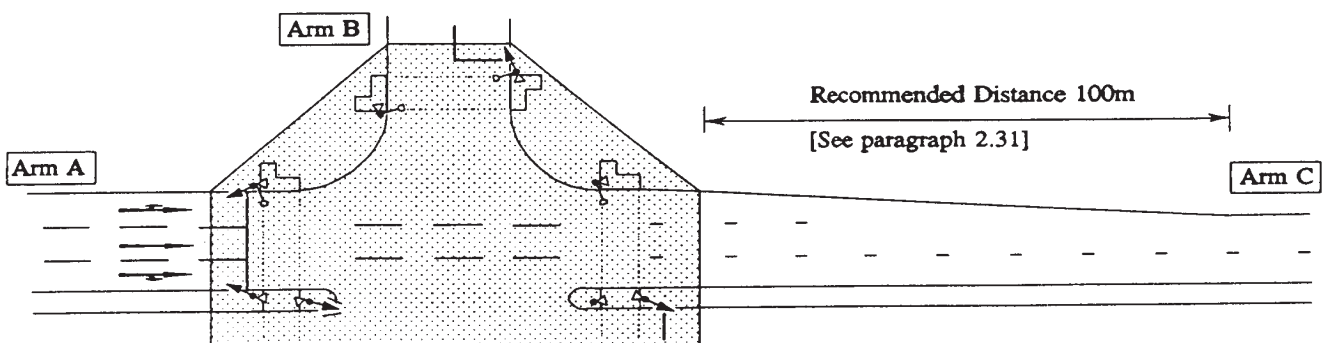

Figure 2/11: Lane Continuity Through Junction Intervisibility Zone

Swept Path Requirements

2.34 The swept path requirements of the **Design Vehicle** are defined in **TD 42 (DMRB 6.2.6)**.

2.35 The nature of the signal-controlled junction and its associated splitter islands and pedestrian refuges may restrict the movement of vehicles, particularly large goods vehicles, and allowance shall be made for the swept turning paths of the design vehicle where provision is to be made for large goods vehicles.

2.36 It is essential to ensure that adequate turning radii are provided for the swept paths of all types of vehicles using the junction and the swept paths should be checked for all permitted turning movements. **Figures 2/12 and 2/13** indicate examples of swept paths to illustrate the general requirements.

2.37 The assessment of swept paths using simple templates or overlays is not recommended as they do not adequately predict the swept paths of the vehicles

for non-standard situations. The use of computer simulated models of the vehicles and their movements which can be interactively superimposed upon a computer generated design model of the junction is preferred. The use of computer simulated models to predict swept paths may assist the designer to minimise the required widening within the junction. This may identify areas of superfluous carriageway [See **Figure 2/12**] which can be effectively removed to provide greater footway width for pedestrians, or to minimise the required widening and hence construction costs.

2.38 The nosing of central reserves and pedestrian refuges should be set back a minimum distance of 1.5m, measured from a line extended from the edge of the intersecting road as indicated in **Figures 2/5, 2/8, 2/9 and 5/1**.

2.39 Adequate clearance between the edge of carriageway and any street furniture (including signal heads, backing boards and subsidiary signal heads) is needed to prevent damage by vehicles having a lateral overhang. A minimum clearance of 450mm should be provided. Additional clearance may be required where the crossfall of the carriageway is greater than 2.5%.

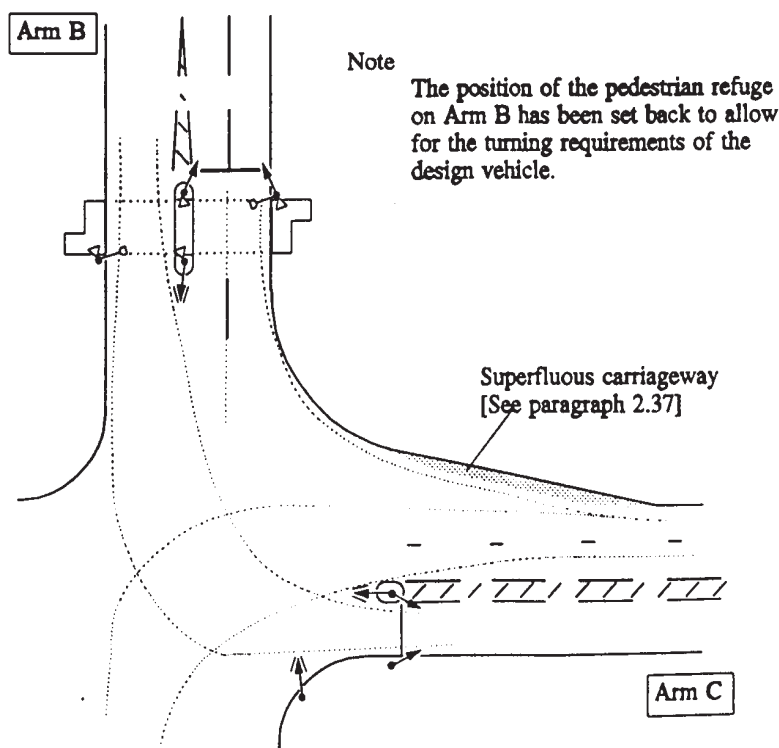

Figure 2/12: Examples of Swept Paths

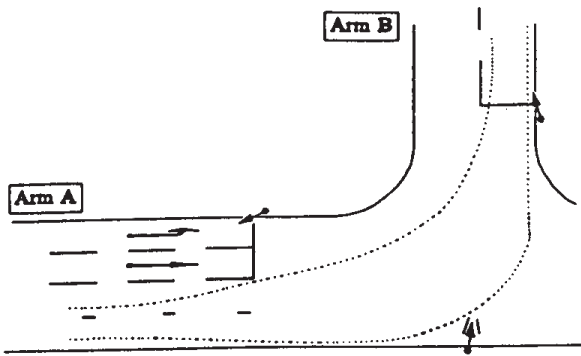

Figure 2/13: Setting Back Stop-Lines

2.40 Where no provision is specifically made for large goods vehicles they may have difficulty in completing a manoeuvre without encroaching into opposing lanes. When this is likely it may be necessary to set back the stop-line (and crossings if present) where the conflict would occur, as indicated in **Figure 2/13**. Stop-lines on adjacent entry lanes should not be staggered as large goods vehicles in the nearside entry lane may prevent vehicles in the offside entry lane seeing the nearside primary signal or pedestrians.

2.41 In difficult confined situations the channel and footway opposite the minor road may be set back to provide additional carriageway for the swept path of the large goods vehicle as indicated in **Figure 2/14**.

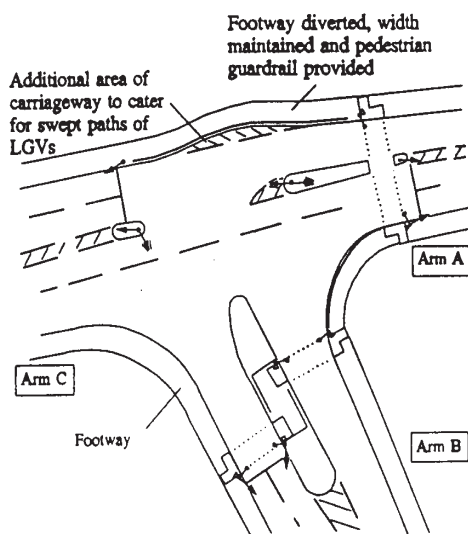

Figure 2/14: Localised Widening at T Junction

Left-Turn Slip Lanes

2.42 **Figure 2/15** illustrates an example of a left turn slip lane and separation island typical of a situation where the proportion of left turning traffic is low and large goods vehicles are expected infrequently. Large goods vehicles which experience difficulty turning may encroach into the entry lane (**Arm C**), causing conflict. Where the proportion of large goods vehicles is significant, adjusting the corner radius, providing a taper and setting the stop-line back, as indicated in **Figure 2/16**, should be considered to reduce the conflict.

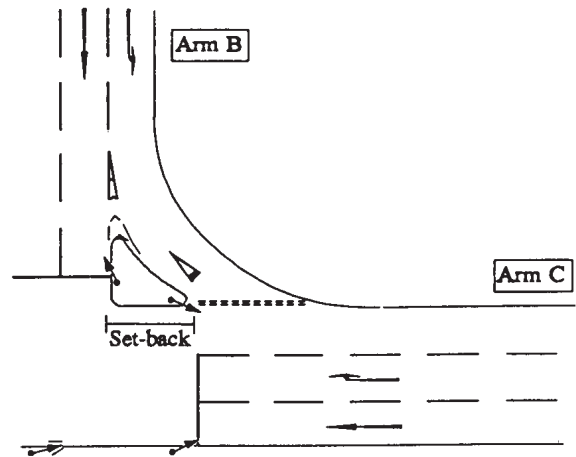

Figure 2/15: Left-Turn Slip Lane (without taper)

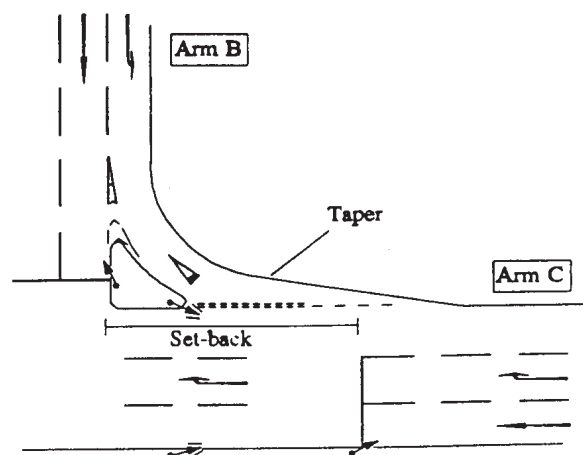

Figure 2/16: Left-Turn Slip Lane (with taper)

2.43 Left turn slip lanes may be signal-controlled or uncontrolled. A consistent approach to the layout of the slip lanes and their associated pedestrian crossing facilities should be adopted. Individual junction layouts should not mix uncontrolled and controlled crossings where they combine to form a single pedestrian crossing route [See **Figures 5/2 and 5/4**].

2.44 Uncontrolled left turn slip lanes may make crossing for pedestrians more difficult as a result of increased vehicle speeds, and it is important to consider the whole effect of the geometric layout upon pedestrian crossing facilities. The effect of the taper, crossing lengths and pedestrian desire lines should be considered when identifying the locations for pedestrian crossings.

2.45 Left turn slip lanes with a separation island should be considered where:

- a. the left turn traffic movement is high;
- b. left turn manoeuvres for large goods vehicles need to be facilitated;
- c. delay for left turn vehicles would otherwise be significant;
- d. left turn traffic capacity requirements would extend the green time required for the straight ahead traffic movement phase.

Separation Islands

2.46 Separation islands shall be provided to separate uncontrolled traffic from controlled traffic where left turn slip lanes are provided, as indicated in **Figure 2/15**.

2.47 Separation islands may also be provided in other situations to separate two independently controlled lanes of traffic on the same entry, as indicated in **Figure 5/9**.

2.48 Separation islands which also act as refuges for pedestrians should be designed to accommodate pedestrian refuge crossing facilities and associated equipment [See **Paragraph 2.39**] and should be uniformly lit to current standards. Separation islands can assist in providing safe crossings for pedestrians whilst improving traffic capacity by the incorporation of pedestrian call stages, as illustrated in **Figure 4/2**.

2.49 Guidance on the geometric requirements for pedestrian refuges is contained in **Chapter 4** of this document.

Right-Turning Traffic Movements

2.50 Accidents at signal-controlled junctions can occur as a result of conflict arising from right turning traffic movements. If local circumstances permit, right turn movements may be banned. Alternatively a number of signalling techniques may be employed to control the right turn movements and these techniques should be considered at an early stage of the design to determine the appropriate measures.

2.51 Where the 85th percentile approach speed is greater than 72kph (45mph) there is an increased risk of accidents between right-turning vehicles seeking gaps and on-coming vehicles travelling at speed. It is recommended in such situations that right-turns should be separately signalled [See **TA 12 (DMRB 8.1.1)**].

Non-Hooking Arrangements

2.52 Where opposing right turn lanes can be aligned directly opposite each other turning movements are improved with right turn traffic passing nearside to nearside (non-hooking) as illustrated in **Figures 2/17 and 2/18**. Non-hooking road markings permit a small number of right turning vehicles to wait within the junction intervisibility zone.

2.53 **Figure 2/17** illustrates an arrangement where the central reserves on the major road are offset to facilitate non-hooking turning movements on the major road phase or a separate right turn phase.

2.54 **Figure 2/18** shows the right turning lane separately signalled and segregated from the adjacent ahead-only traffic by a traffic island. This feature is recommended on high speed roads and can be adopted in other cases if local circumstances permit.

2.55 **Figure 1/1** illustrates an example of a non-hooking arrangement with separation islands provided to deflect the right turning traffic at a junction which is subject to geometric constraints.

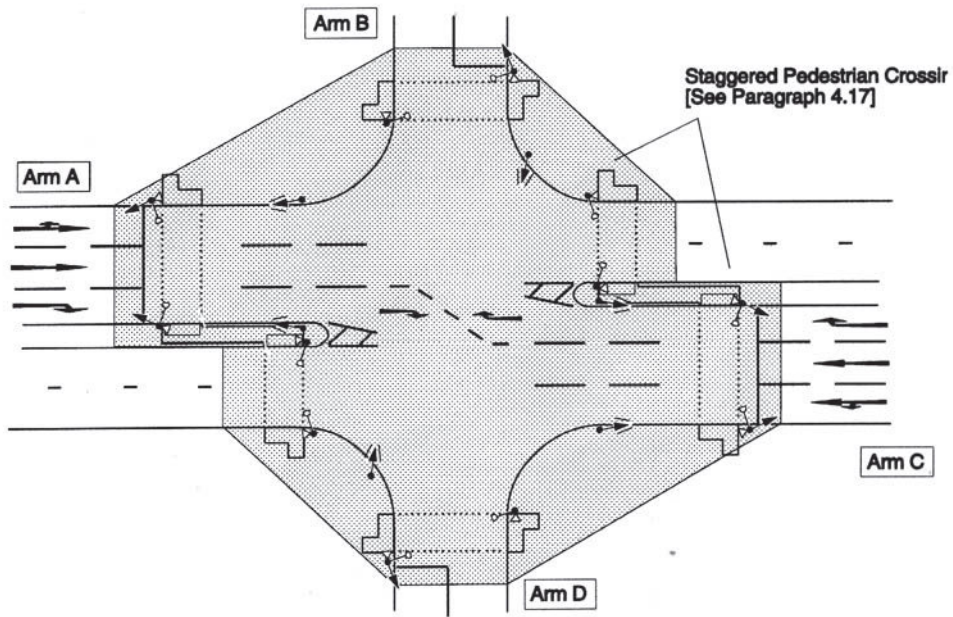

Figure 2/17: Offset Non-Hooking Arrangement

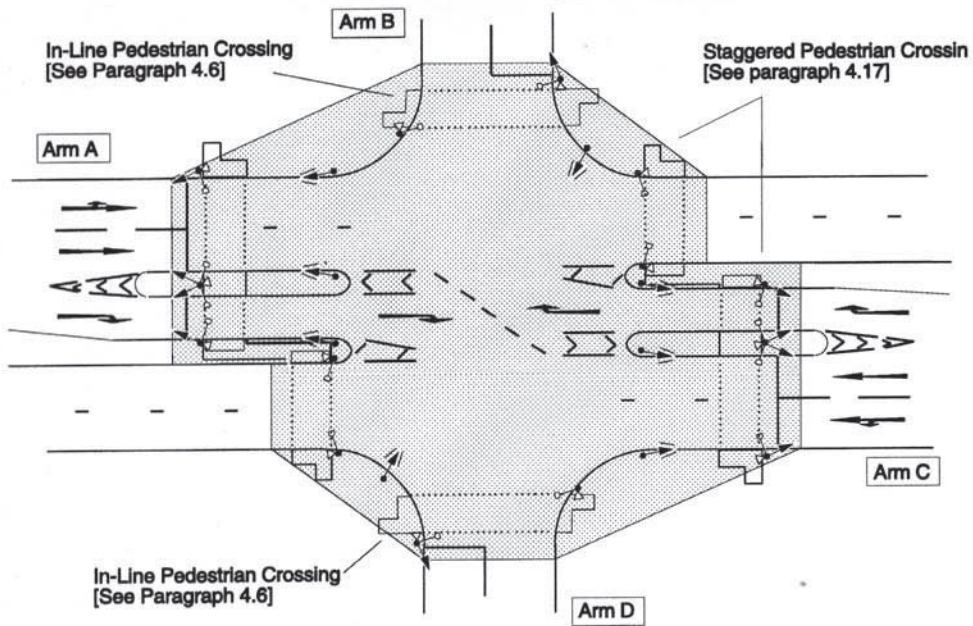

Figure 2/18: Aligned Non-Hooking Arrangement

Traffic Signs and Road Markings

2.56 Traffic signs and road markings (including yellow box markings) are specified in **Chapter 5 of the Traffic Signs Manual**, the **Traffic Signs Regulations and General Directions (TSRGD) 1994** and the **Traffic Signs Regulations (Northern Ireland) 1997 (TSR[NI])**. Advice on the provision of road markings to indicate non-hooking turns is given in **TA 8 (DMRB 8.1.1)**.

High Friction Surfacing (HFS)

2.57 The provision of adequate friction between vehicle tyres and the surfacing on entry carriageways to signal-controlled junctions reduces the potential for accidents to occur.

2.58 The requirements for Polished Stone Value and Aggregate Abrasion Value are given in **HD 28 (DMRB 7.3.1)** and should be used to determine the need for HFS on the carriageway approaches to the junction.

2.59 When HFS is required, it is recommended that it is applied to the wearing course for a minimum length of 50m ahead of the stop-line on all lanes of an approach. The approach speed, accident record, average queue length, proximity of side roads and mix of traffic are all relevant when determining the overall length of the HFS. Any of these factors may result in an increase beyond the minimum length.

2.60 If the signal-controlled junction incorporates pedestrian facilities on any of its arms and the application of HFS is being considered, then it is recommended that the HFS be continued past the stop-line to the first line of crossing studs or marks. In certain circumstances where there are high approach speeds, reduced visibility or a downhill gradient it may be appropriate to carry the HFS through to the second line of crossing studs or marks. If the HFS is taken past the stop-line particular attention must be paid to the colour contrast between the HFS and the bituminous surfacing to ensure high visibility of the stop-line and the crossing studs or marks.

Location of Signals

2.61 There should be at least 2 signals visible from each approach, and stop-line, usually comprising a primary and a secondary. Where separate signalling of turning movements is employed, this advice applies to the approach lane(s) associated with each turning

movement, and a signal post can then display information applicable to more than one turning movement.

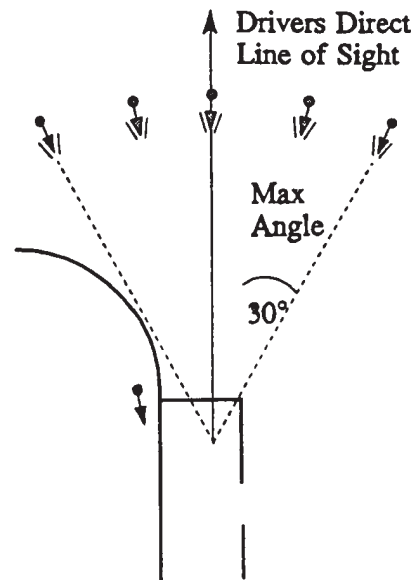

Figure 2/19: Locating Secondary Signals

2.62 Primary signal heads should be located a minimum of 1m beyond the stop-line and in advance of crossing studs or marks if pedestrian facilities are provided. For general advice on signal-controlled pedestrian crossings designers should make reference to **TA 68 (DMRB 8.5.1)**.

2.63 In some circumstances it may not be possible to locate the secondary signal in the direct line of sight of the driver. For example at junctions with angled approaches the maximum angle that the secondary signal should be displaced is 30° from the driver's line of forward sight, as indicated in **Figure 2/19**.

2.64 The distance between the stop-line and an associated secondary signal should not exceed 50m.

2.65 Where mast arms are being considered, any technical approval and the requirements for the mast arm foundation and maintenance requirements should all be determined at an early stage of the layout design.

2.66 Care must be exercised when providing multi phased signal layouts, as indicated in **Figure 5/1** where a displaced pedestrian crossing is illustrated, to avoid "see through" where traffic (at point X) may be confused by the signal at the next stop-line (point Y).

An additional secondary signal should be considered in such circumstances.

Landscaping

2.67 The design of landscaping within the highway limits should be carried out in consultation with appropriate specialists. The Design Organisation shall consider the maintenance implications and where the maintenance is passed to a third party, maintenance standards must be agreed. If third parties wish to enhance the standard of planting or landscaping at a signal-controlled junction, for example with floral displays, this shall be with the agreement of the Overseeing Organisation, and should not compromise visibility, safety or pedestrian, cyclist and equestrian convenience. Further advice is given in **DMRB Volume 10 (Sections 1 and 3)**.

2.68 The transparency of pedestrian guardrail should not be compromised by placing ornamental objects near the pedestrian crossings or attaching them onto pedestrian guardrails.

Maintenance

2.69 The position of the controller cabinet should be considered at an early stage of the design, to ensure that adequate visibility from the controller cabinet to the signal head and stop-line is provided for each junction arm. The controller cabinet should not be situated such that it causes either physical or visual obstruction to road users and pedestrians.

2.70 When determining the junction layout it is important to consider access and parking arrangements for the servicing of the signal equipment.

3. SAFETY

General Principles

3.1 The purpose of signal control is to obtain the most efficient use of available road space combined with the maximum safety for all road users using the junction. This chapter highlights those geometric design features which have a direct effect upon safety and provides additional guidance on good design practice to enhance safety. Additional guidance is contained in the publication **Code of Practice for Traffic Control and Information Systems**.

Accidents

3.2 The majority of accidents occur at or in the vicinity of junctions.

3.3 Existing accident rates should be quantified, conflicts identified and accident rates predicted (opening and design years) for the proposed layout, in order to determine achievable benefits with regard to safety.

3.4 The installation of signal control at an existing priority junction is often the concluding action of a detailed accident study. Designers should take account of recommendations made by the accident investigation team and identify items of the junction layout and furniture, such as signing, lighting and surfacing which, if improved, may assist in lowering the accident rate.

Good Design Practice

3.5 In addition to signalling techniques and the method of control, inclusion of certain design features in junction layouts can, in some situations, positively influence the overall safety of a junction. The designer may consider using these features singly or in combination but should assess their likely value and effectiveness for individual sites. Examples are:

- a. use of types of guardrail giving intervisibility between drivers and pedestrians (including small children and push chairs);
- b. provision of an island/refuge to accommodate secondary or offside primary signals;
- c. improved horizontal and vertical alignments on the approaches to increase visibility;

- d. high friction surfacing on the immediate approaches to the signals on roads with high approach speeds;
- e. clear and unambiguous traffic signs and road markings on the approaches to guide drivers into the correct lanes;
- f. carriageway markings to promote non-hooking right-turn movements;
- g. removal of right turn movements, if feasible;
- h. fitting crossing routes to pedestrian desire lines, and using guardrail to guide pedestrians;
- i. provisions for disabled pedestrians such as audible and tactile devices;
- j. specific measures for cyclists;
- k. road lighting;
- l. use of barrier kerbs to restrain large goods vehicles and prevent damage or danger caused by vehicle overhang;
- m. the provision of backing boards to signal heads will improve clarity of signals in different light conditions.

Controller Settings

3.6 Guidance on the controller settings which have an important effect upon safety is contained in **DMRB 8.1**, as identified below:

- a. intergreen periods;
- b. minimum green periods;
- c. vehicle actuated extension times;
- d. queue detection.

Road Lighting

3.7 Guidance on road lighting is contained in **TD 30 (DMRB 8.3.3)**.

3.8 Illuminated bollards, signs and lighting columns should be placed so that they do not detract from the conspicuousness of signal heads and it is essential that the lighting requirements are considered at an early stage in order to fully incorporate them into the design.

3.9 The location of lighting columns should be assessed to ensure they do not cause obstruction to signal heads or associated signing.

3.10 The effect of illumination from other sources such as adjacent commercial properties should be taken into account when considering the position and type of signal heads. Visibility of the signal head can also be adversely affected at sunrise and sunset. Measures can be taken to alleviate some of these problems and should be considered at an early stage of the design.

- h. proposals for other junctions within the immediate vicinity;
- i. alternative forms of junction;
- j. other means of traffic control (including level crossings);
- k. is the junction within, or close to, an Urban Traffic Control Area;
- l. is the junction within a light rapid transit area;
- m. cyclist/equestrian facilities;
- n. is the junction on an abnormal load route.

High Friction Surfacing (HFS)

3.11 **HD 28 (DMRB 7.3.1)** is used to determine the need for HFS on the carriageway approaches to a junction. If HFS is needed there may be a delay between the laying of new surfacing and the application of HFS material. This can mean that the high level of skid resistance specified in **HD 28 (DMRB 7.3.1)** may not be available in that intervening period, resulting in an increase in the possibility of shunt or wet weather accidents. It may therefore be appropriate to take preventative action for this period, such as delaying the commissioning of the signals, or erecting appropriate warning signs indicating slippery road ahead.

Other Design Criteria

3.12 Other factors to be considered during the design process include:

- a. classified traffic flows and proportion of large goods vehicles;
- b. traffic movements;
- c. pedestrian flows and facilities;
- d. vehicle detection equipment;
- e. early cut-off/late start operation (late release);
- f. accident statistics;
- g. proximity of other junctions and pedestrian crossing facilities;

4. ROAD USERS' SPECIFIC REQUIREMENTS

General

4.1 When signal control is being considered the extent of pedestrian crossing movements, cyclist and equestrian usage, and bus movements should be determined and the provision of specific measures included unless site specific considerations warrant their exclusion.

4.2 Provisions for pedestrians, cyclists, equestrians and buses may require additional signing in accordance with the **Traffic Signs Regulations and General Directions (TSRGD) 1994**, the **Traffic Signs Regulations Northern Ireland (TSR[NI])** or may require special authorisation by the Secretary of State. Designers should make reference to the **Department of the Environment, Transport and the Regions (DETR)** publication list which identify recent developments regarding policy on traffic control and management issues.

4.3 **TA 68 (DMRB 8.5.1)** provides advice on the assessment and design of pedestrian crossings as contained in the **Local Transport Notes (LTN)** identified in the **DETR** publication list. References to pedestrians in the **LTNs** should be read to include cyclists and equestrians, however it should be noted that only pedestrians may legally use a pedestrian crossing. Where cyclists are to be permitted to ride across the crossing (this should be at all locations where cyclists are expected to use the crossing places) a **Toucan** crossing should be provided for joint use by pedestrians and cyclists.

Specific Measures for Pedestrians

4.4 Where a pedestrian need is established then appropriate signal controlled facilities should be provided.

4.5 **TA 15 (DMRB 8.1.1)** sets out the measures which can be adopted to assist pedestrians to cross carriageways at signal-controlled junctions and provides guidance on the overall requirements (and dimensions) for staggered and displaced pedestrian crossing facilities. **TA 68 (DMRB 8.5.1)** outlines the requirements for refuge islands and staggered crossings. **TA 57 (DMRB 6.3.3)** contains additional guidance on kerbing and guardrails.

4.6 Pedestrian crossings should normally be located beyond the limits of the junction radius (inset crossings) to minimise the road crossing distance. In some circumstances however, it may not be possible to provide inset crossings and the crossing may need to be positioned within the limits of the junction radii (**in-line crossing**). In these cases, the pedestrian refuge should be located at a minimum offset of 1.5m measured from a line extended from the edge of the intersecting carriageway as indicated in **Figure 2/5**. In-line pedestrian crossings will result in longer pedestrian crossing distances and particular consideration should be given to the problems associated with vulnerable road users.

4.7 **Guidance on the use of Tactile Paving Surfaces** is contained in the advice from the **DETR** Mobility Unit. This provides guidance on the use of dropped kerbs and tactile surfaces at pedestrian crossing points and recommends the type of tactile surface arrangement to be adopted at inset and in-line pedestrian crossings.

4.8 Where pedestrians are expected to cross arms of a junction, tactile surfaces and dropped kerbs shall be provided.

4.9 The provision of tactile paving and tactile devices, audible signals, dropped kerbs and guardrail are all mobility aids designed to assist disabled pedestrians at the crossing. Designers should consult with specialist workers who teach mobility skills to users, to ensure that the use of such aids is not compromised by poor design.

4.10 Pedestrians should be encouraged to use defined points to cross the road. Preferably, crossings should be located to minimise crossing distances and to avoid excessive detours. It may be desirable to restrict the pedestrian crossings to certain approaches at a signal-controlled junction (eg limitations on intervisibility or conflicts with private accesses). Guardrails should be used to discourage pedestrians from crossing at dangerous locations and to channelise them to the appropriate crossing points. The following measures can contribute to improved safety and convenience:

- a. fitting crossing routes to the pedestrian desire lines;
- b. the provision of pedestrian guard rails;
- c. the provision of tactile surfaces to assist pedestrians with impaired vision;
- d. the provision of dropped kerbs to assist wheelchair users;
- e. the provision of pedestrian signal phases;
- f. providing good intervisibility between pedestrians and drivers.

4.11 Where existing junctions are being modified, buildings may obstruct intervisibility [See Paragraphs 2.14 and 2.15] and in these circumstances measures to move the stop-line forward should be considered. This may require pedestrian crossing routes to be diverted away from the immediate junction intervisibility zone (or the provision of inset crossings), and the effect on pedestrian desire lines should be considered.

Pedestrian Refuges and Separation Islands

4.12 Where a pedestrian crossing stage is timed to permit pedestrians to cross a whole carriageway in one movement, then the width of the pedestrian refuge 'w', as indicated in Figure 4/1, shall be 1.5m minimum.

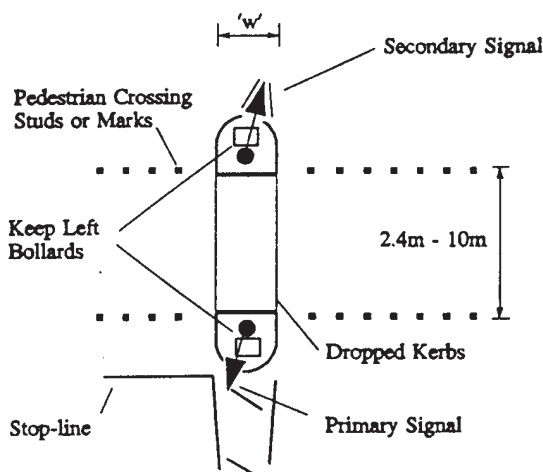

Figure 4/1: Pedestrian Refuge

4.13 Complex patterns or large areas of tactile paving should be avoided, as these may confuse visually impaired pedestrians. A consistent approach should be adopted for all separation islands within an individual junction layout.

4.14 Tactile surfacing at the extremities of pedestrian crossing places shall be laid in the "L" shape pattern. Tactile surfacing is not recommended within pedestrian refuges or separation islands where the signal staging is intended to allow pedestrians to cross the whole width of the carriageway in one movement [See Chapter 4.7].

Crossing Places

4.15 The crossing place should be indicated by two rows of studs or marks each of the dimensions given in **TSRGD** and **TSR[NI]**, and set out as shown in Diagram 1055 of the Regulations. The Regulations state that the minimum width of the crossing place is 2.4m. The width of the crossing place is dependent on the site conditions but is normally in the range 2.4 to 5 metres. Usage by large numbers of pedestrians may require the width to be increased up to 10.0m. **Toucan** crossings should be a minimum of 3.0m wide and preferably 4.0m wide. The crossing place should be designed to a width which avoids the need for unnecessary cutting of the tactile paving units and dropped kerbs.

4.16 Pedestrian crossings should be perpendicular to the edge of the carriageway to assist intervisibility and benefit visually impaired people [See Figure 4/2]. However in some circumstances it may be necessary to provide them at a skew angle. In all circumstances, the tactile paving should be correctly aligned to direct visually impaired people safely across the crossing. To achieve this the upright of the "L" shape shall always be aligned in the direction of the crossing [See Chapter 4.7].

4.17 **TA 68 (DMRB 8.5.1)** provides guidance on the assessment and design of pedestrian crossings. The preferred orientation of staggered pedestrian crossing facilities is such that pedestrians within the central reserve are facing oncoming traffic as they approach the crossing, as illustrated in **Figures 2/17 and 2/18**. In some circumstances, due to geometric or capacity constraints and the pedestrian desire lines, this may not be achievable, as illustrated in **Figure 5/3 (Arm A)** and **Figure 5/4 (Arm C)**.

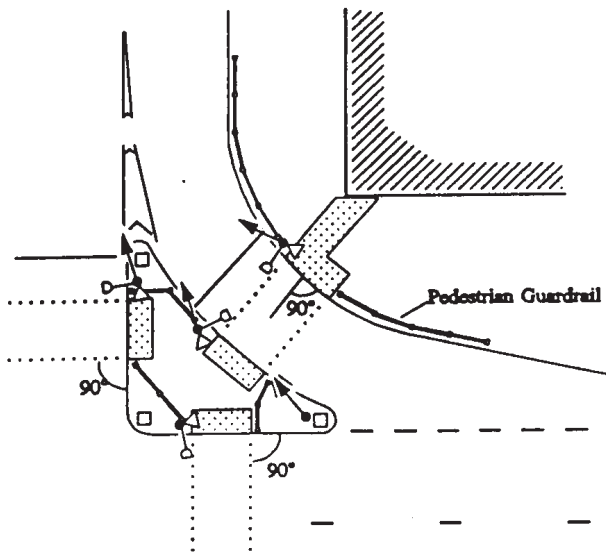

Figure 4/2: Pedestrian Crossing Facilities on Separation Island

Specific Measures for Cyclists

4.18 Additional information on the provision of dedicated cyclist facilities is contained in the documents referred to in the **DETR** publication list and **TA 68 (DMRB 8.5.1)**.

4.19 Along main traffic routes, the provision of cycle lanes to separate cyclists from other vehicular traffic and delineate clear routes may be appropriate and those measures which should be considered are:

- a. mandatory cycles lanes, which exclude other vehicles;
- b. advisory cycle lanes, which do not exclude other users and which may be more appropriate where space is restricted;
- c. cycletracks.

4.20 Advance stop-lines for cyclists [See **Figure 4/3**] may be beneficial, enabling cyclists to:

- a. position themselves ahead of other traffic;
- b. assist turning manoeuvres;
- c. be more visible to motorists;
- d. clear the junction before other vehicles.

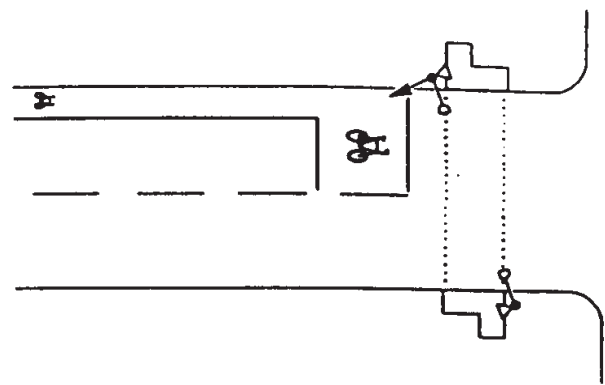

Figure 4/3: Advance Stop-Line for Cyclists

4.21 At cycle tracks, Toucan crossings provide a controlled combined crossing for cyclists and pedestrians.

Bus Lanes

4.22 The documents referred to in the **DETR** publication list provide advice and design guidance on traffic management methods which may be used to assist buses at signal-controlled junctions. These include:

- a. **withflow** bus lanes which are terminated in advance of the stop-line to ensure that the full width of the stop line is available to all traffic during the green period, thereby minimising delays to other traffic and accommodate left turns [See **Figure 5/3**];
- b. **contraflow** bus lanes permit buses to travel against the main direction of traffic flow in oneway streets, thereby avoiding unnecessary diversions and providing improved access;
- c. **turning exemption**, allowing buses to make a turn which is prohibited to other traffic;
- d. **selective detection** giving priority to buses fitted with a transponder which is recognised by the signal controller;
- e. on withflow bus lanes, **separate traffic signals** can be installed at the termination of the bus lane, in advance of the main junction intervisibility zone, providing a **bus advance area** between the two sets of signal control.

4.23 Where contraflow lanes are reserved for buses and cyclists on one-way roads they shall be separated from other traffic by a traffic island on the exit from the traffic intervisibility zone.

4.24 Cyclists are normally permitted to use withflow bus lanes. Other classes of vehicles which may be permitted to use bus lanes in certain circumstances, provided Traffic Regulation Orders are implemented, include emergency vehicles, motor cycles, taxis and goods vehicles.

Specific Measures for Equestrians

4.25 Special authorization is required for signal controlled crossings incorporating equestrian facilities.

4.26 Additional information on provision for equestrians is contained in **TA 57 (DMRB 6.3.3)** and **TA 68 (DMRB 8.5.1)**.

4.27 Where specific measures are being considered for equestrians it is important to recognise that the reaction of horses is not predictable and that when startled or upset they may act defensively or try to take flight, which can make control difficult for the rider. Designers should consider the effect of such behaviour on other road users when providing specific measures for equestrians. The following measures, should be considered for equestrians:

- a. increase eye height to 2.7m when considering visibility requirements for riders;
- b. avoid situating crossing points in soft verges which contain dangerous items such as manholes, gullies and ditches;
- c. ensure that there is sufficient verge width to accommodate the horse(s);
- d. avoid excessive use of large roadmarkings on the carriageway or crossing, which can disturb horses;
- e. avoid locating crossings where sudden noises are likely to occur;
- f. push button units should be installed at 2.0m height for mounted equestrians with additional units at standard height for the dismounted rider leading the horse;

- g. staggered crossings are not advised for equestrians;
- h. timings should take into account the special needs of equestrians and the additional intergreen period;
- i. segregation of equestrians from pedestrians and cyclists.

4.28 **Figure 4/4** illustrates an example of a segregated pedestrian/equestrian crossing where a bridleway approaches and crosses a single carriageway.

4.29 **TA 68 (DMRB 8.5.1)** does not encourage the use of central refuges on single carriageway roads, however where a signalled equestrian crossing is being provided the use of central islands with a single stage crossing may be considered appropriate, to:

- a. focus drivers' attention on the crossing;
- b. prevent overtaking;
- c. act as a speed reduction measure.

4.30 **TA 57 (DMRB 6.3)** recommends that uncontrolled at-grade equestrian crossings of dual carriageways are not provided. When determining the requirements for bridleways Designers should consider diversions to avoid the need to cross the dual carriageway at-grade. Where diversions cannot be provided, Designers should consult with local equestrian groups and the Overseeing Organisation before proceeding with proposals for controlled crossings [**See Paragraph 4.27**].

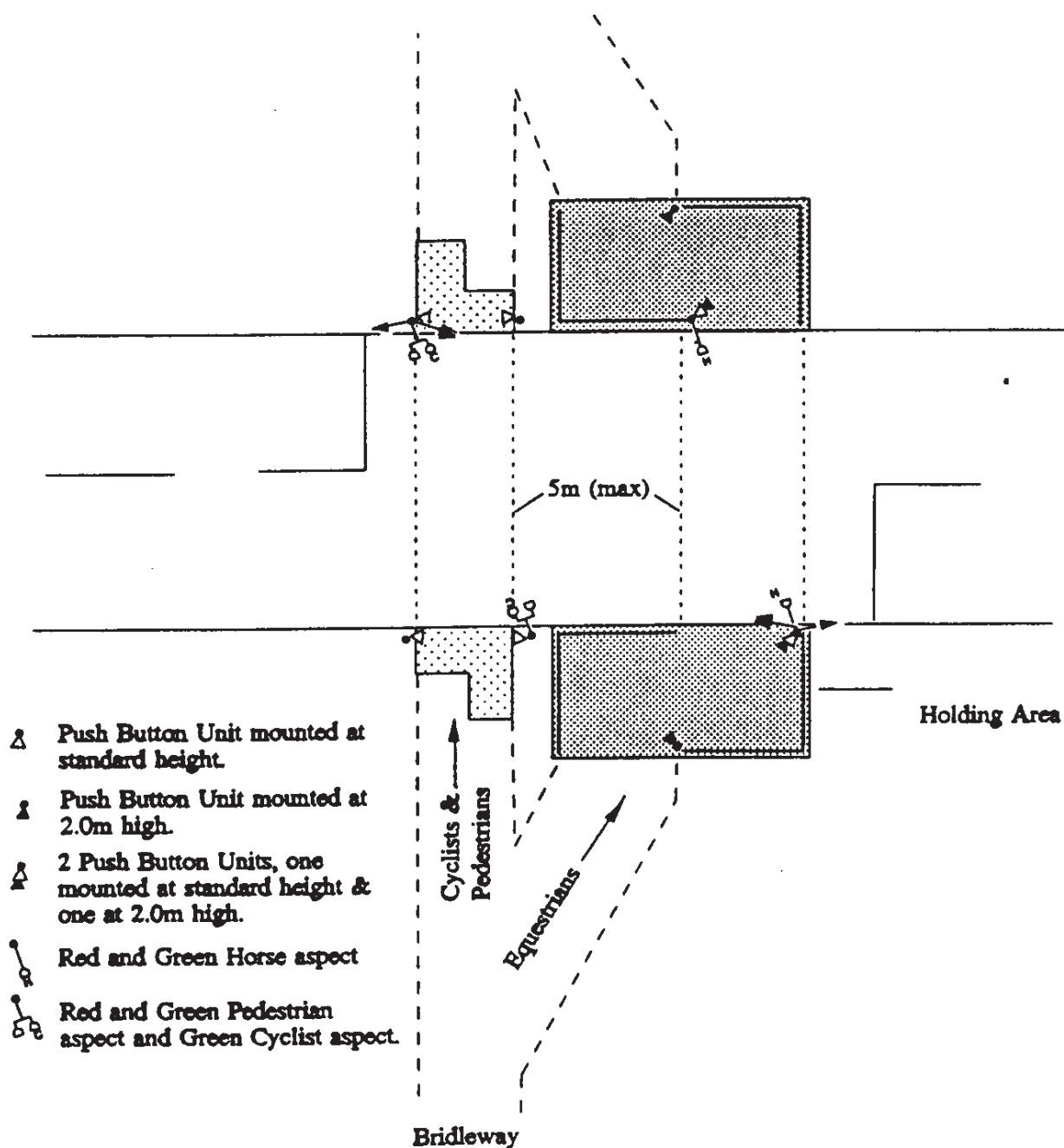

Figure 4/4: Combined Toucan and Equestrian Crossing

5. JUNCTION ARRANGEMENTS AND OPERATION

General Principles

5.1 This chapter provides figures to illustrate examples of signal-controlled junctions. It is not possible to illustrate all variations in junction arrangements and designers will be required to develop particular solutions to suit site conditions. In some of the figures, pedestrian facilities have been omitted for the purpose of clarity and in order to demonstrate that pedestrian facilities may not be appropriate or possible in some circumstances [See **Chapter 4**].

5.2 For the purpose of clarity, pedestrian guardrail has not been indicated on the examples illustrated [See **Chapter 4**].

5.3 Complex layouts for signal-controlled junctions should be avoided and it is desirable to adopt the simplest solution appropriate to the junction. The size and complexity of a junction is dependent on the combination of geometric design features described in **Chapter 2**, and the number of phases, stages and separately signalled movements.

5.4 When designing signal-controlled junctions the designer should ensure that drivers:

- a. have sufficient advance warning to know exactly which route to take at the junction;
- b. are then guided into the intended lane (or lanes) by road markings and signs;
- c. have a clear view of the signals at the junction;
- d. have a clear view of pedestrian crossing facilities on their approach and departure;
- e. have adequate intervisibility within the junction intervisibility zone.

5.5 Existing priority junctions such as simple T-junctions, crossroads and roundabouts can often be modified to accommodate the requirements of signal control more readily than staggered junctions, skew junctions or those with more than four arms.

Classified Traffic Counts

5.6 Classified traffic counts (including pedestrians, equestrians and cyclists) for all proposed operating conditions, including off-peak, should be undertaken in order to assess the junction operation for both opening and design years. It is important that confidence can be placed in both the peak and off-peak period flows used for signal control design purposes, particularly where part-time signals are to be used. The junction layout and arrangement should be designed to achieve a safe efficient layout and signalling system to cater for all road users.

Signal-Controlled T-junctions

5.7 **Figure 5/1** illustrates a simple, small urban signal-controlled T-junction, typical of a situation where available road space may be restricted and the presence of large goods vehicles in significant proportions is not expected. For the purpose of this example it is assumed that the low pedestrian movements combined with the requirement to provide a right turn from Arm C to Arm B have led to a decision not to provide a pedestrian crossing on Arm C. The following specific design features are incorporated into the example:

- a. circular corner radii without tapers (no provision for swept paths of large goods vehicles);
- b. a ‘displaced’ pedestrian crossing on Arm B linked to the junction signals;
- c. an in-line pedestrian crossing on Arm A.

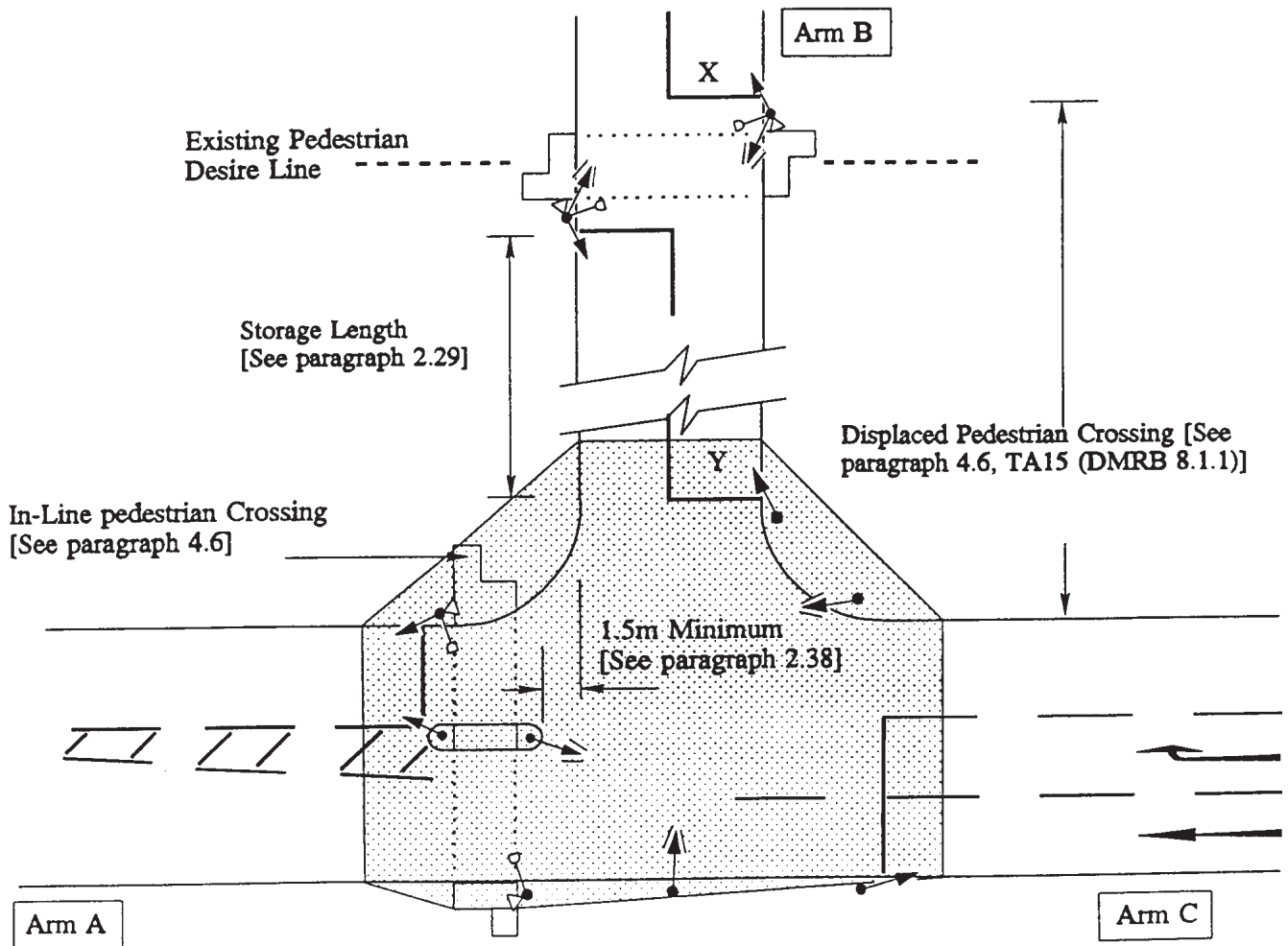

Figure 5/1: Example of a Small Signal-Controlled T-Junction

5.8 **Figure 5/2** indicates an example of a large urban or larger rural signal-controlled T-junction between two dual carriageways, typical of a situation where available road space is not severely restricted, and a significant proportion of Large Goods Vehicles is anticipated on all arms. In this example however, it is assumed that a pedestrian crossing cannot be provided on Arm A due to localised physical constraints. The following specific design features are incorporated into the example:

- a. signal-controlled left turn slip lanes [See Paragraph 2.43] and separation islands (Arm A to B and B to C);
- b. larger corner radii with tapers (provision for swept paths of large goods vehicles);
- c. all staggered pedestrian crossings are indicated in the preferred orientation;
- d. roadmarkings provided to channelise traffic;
- e. additional pedestrian guardrail between points X and Y to guide pedestrians to crossings (not indicated).

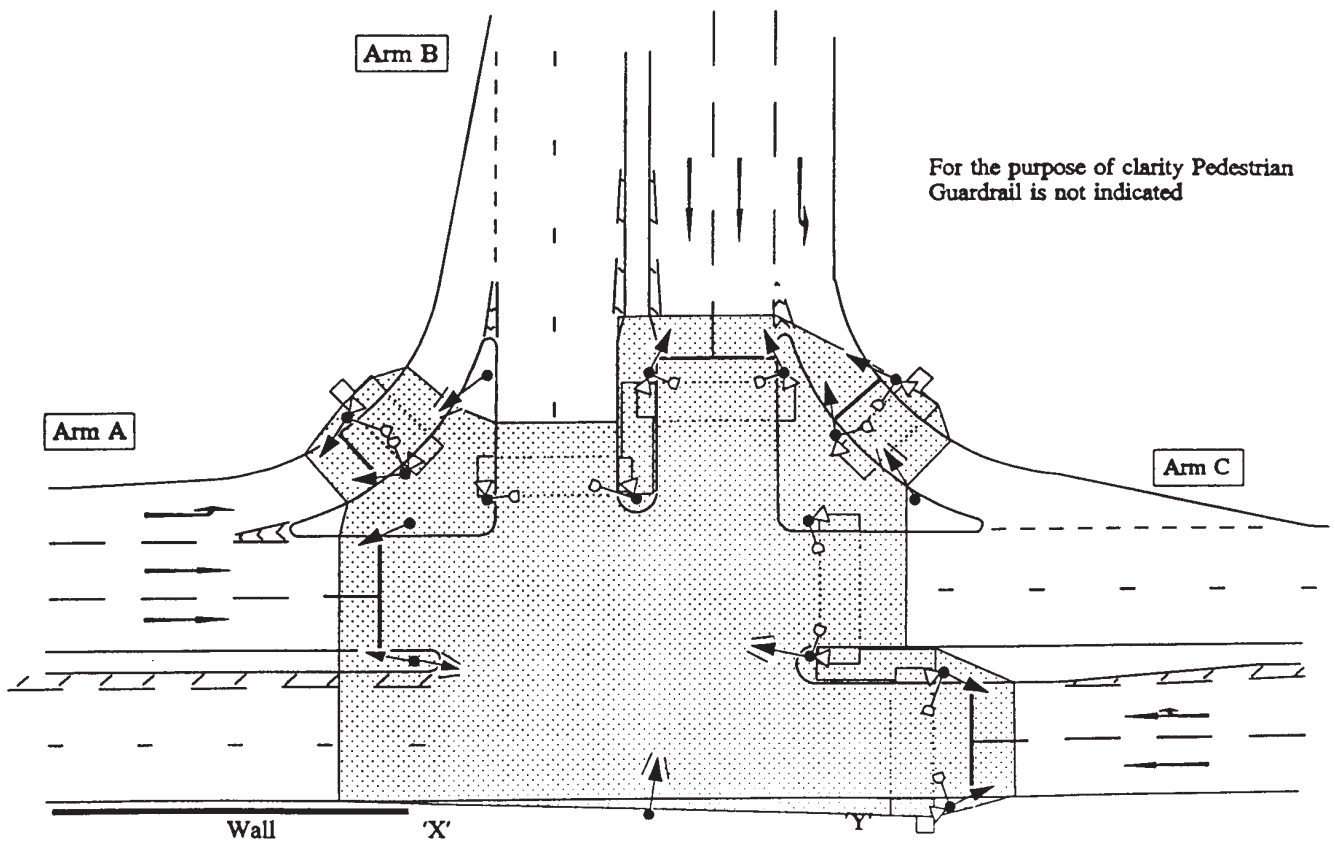

Figure 5/2: Example of a Large Signal-Controlled T-Junction

Signal-Controlled Crossroads

5.9 **Figure 5/3** illustrates an example of an urban signal-controlled crossroads, typical of a situation where available road space is restricted but there is sufficient width to provide a localised central reserve on the major road. The presence of large goods vehicles in significant proportions is not expected and the major road is an important bus route. The following design features are incorporated into the example:

- a. localised widening on the major road to facilitate a staggered pedestrian crossing facility;

- b. circular corner radii without tapers (no provision for large goods vehicles);
- c. bus lane discontinued on approach to junction (Arm A).

5.10 In **Figure 5/3** the bus lane has been terminated in advance of the junction intervisibility zone and the associated pedestrian crossing. In this example, the staggered pedestrian crossing, which is part of the junction signal operation, is not in the preferred orientation [See Paragraph 4.17].

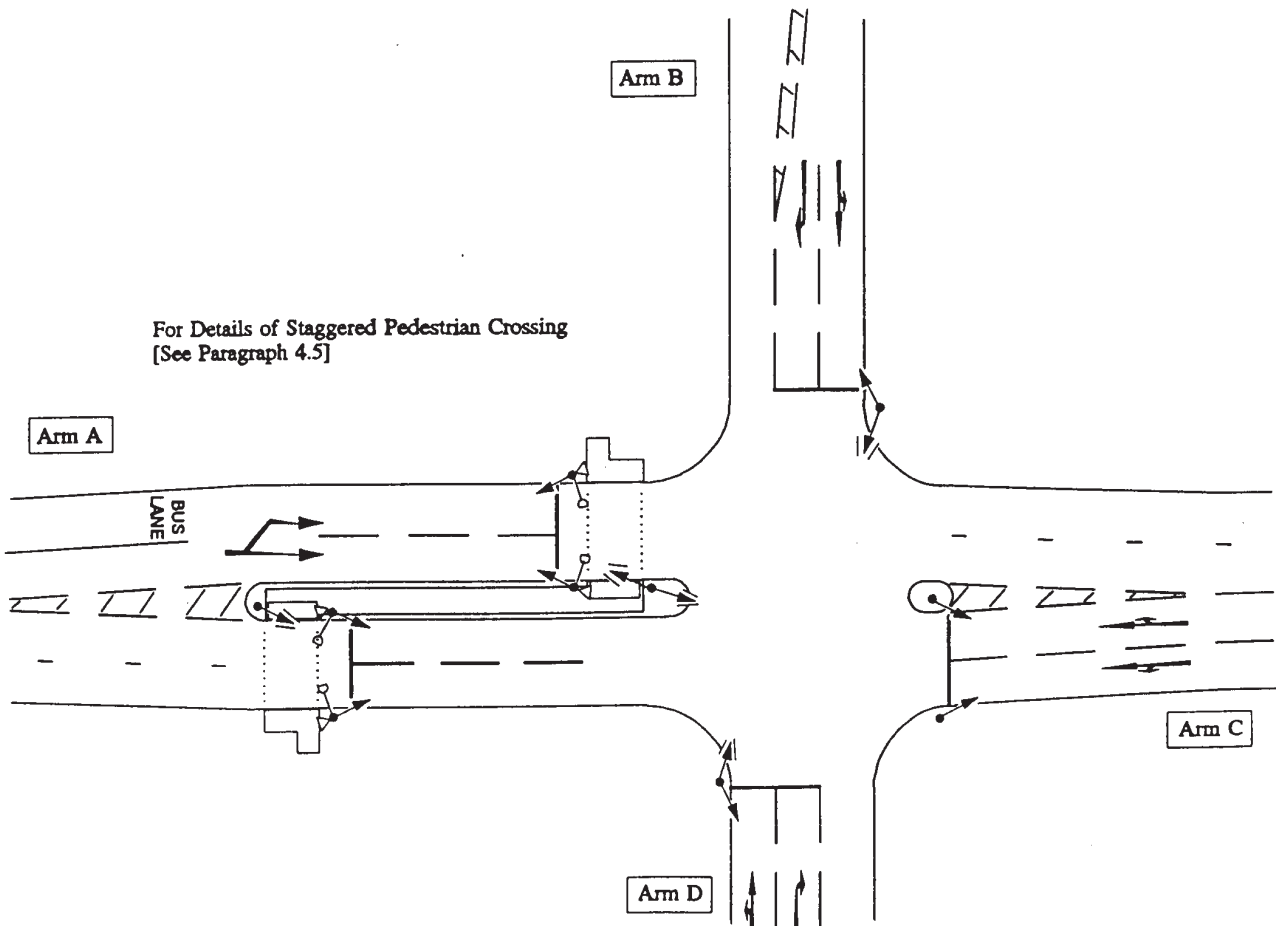

Figure 5/3: Example of a Signal-Controlled Crossroads with a Staggered Pedestrian Crossing

5.11 **Figure 5/4** illustrates an example of a larger, more complex urban or rural signal-controlled crossroad junction between two major dual carriageways. This example is intended to illustrate a situation where, although available road space is not generally restricted, there are some physical constraints which impose limitations on the turning provisions, junction intervisibility and the orientation of the staggered pedestrian crossings. The following design features are incorporated into the example:

- a. uncontrolled left turn slip lane (A to B), circular radius without tapers (Arm B to C), controlled left turn slip lane (C to D) and left turn ban (Arm D to A);
- b. due to the constraints imposed by the separation island, the staggered pedestrian crossing on Arm C is not the preferred orientation;
- c. the staggered pedestrian crossing on Arm D indicates the preferred orientation.

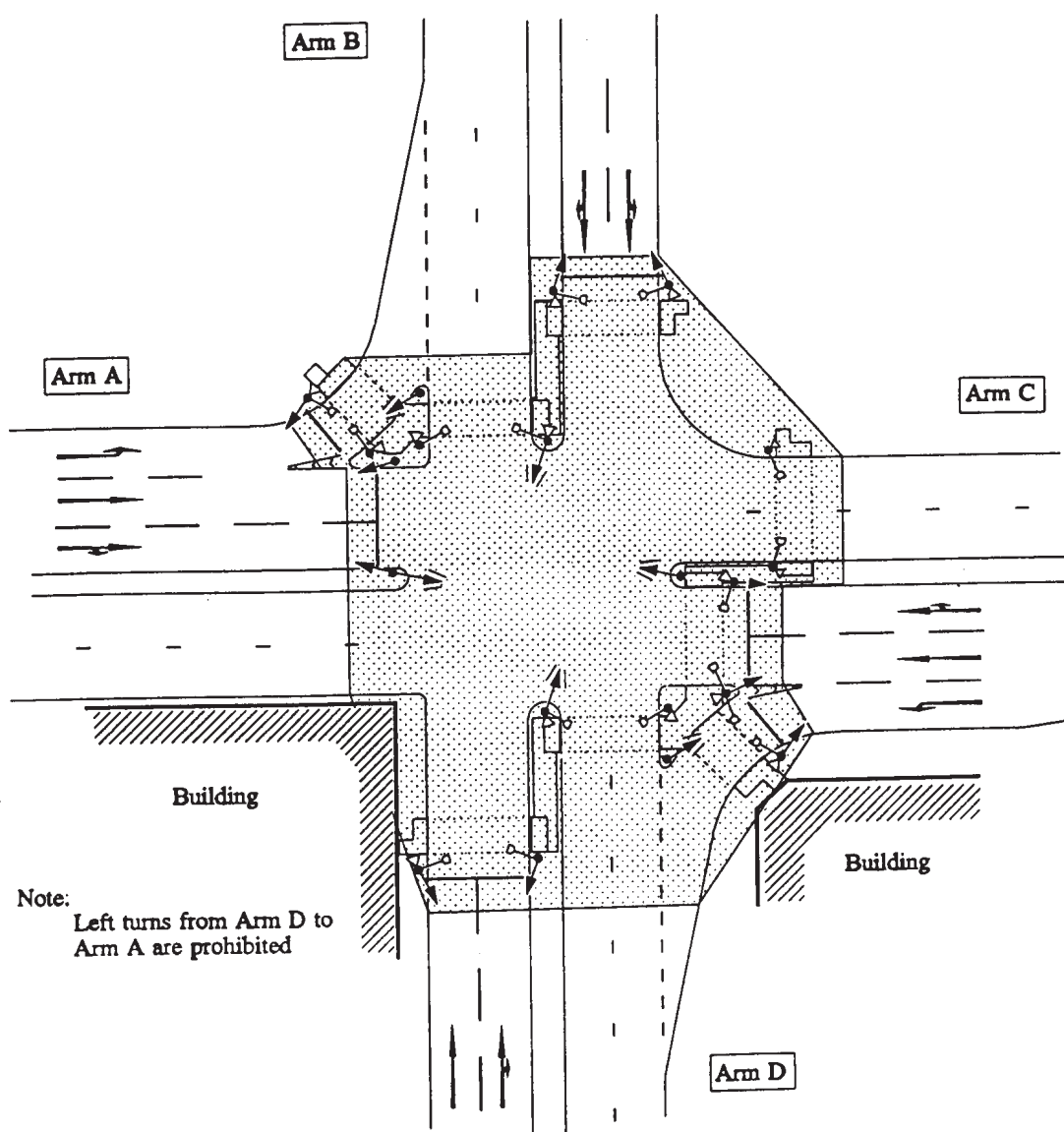

Figure 5/4: Example of a Large Signal-Controlled Crossroad

Signal-Controlled Staggered Junctions

5.12 Signal-controlled staggered junctions may be right/left or left/right as indicated in **Figures 5/6** and **5/7** respectively. Both arrangements for signal-controlled staggered junctions present their own problems with respect to signal control (**TA 16 (DMRB 8.1.1)**) and as a prerequisite to design, traffic management techniques should be considered to eliminate or reduce these problems. No two junctions are alike in these respects and general guidance only can be provided. **Figure 5/5** illustrates the terminology used to describe staggered junctions and for the purpose of clarity no pedestrian facilities are indicated.

5.13 The combination of turning movements from each individual traffic lane and the geometric constraints imposed by the junction may cause junction blocking where insufficient reservoir length is provided. This can result in traffic congestion and conflict and thereby reduce junction safety for all road users.

Stagger Distances

5.14 The stagger distance at a junction is the distance along the major road between the centre-lines of the two minor roads as indicated in **Figure 5/5** and has a

major influence on safety and capacity. A large stagger may result in the arrangement needing to be treated as two separately signal-controlled junctions, whereas a small stagger, possibly with a banned turn, may allow the junction to be treated as a simple signal-controlled crossroad. The stagger distances will usually determine the phasing, stages and timing of the traffic signals.

5.15 Where the stagger distance is greater than 250m the junctions should normally be considered as two separate independent signal-controlled T-junctions.

5.16 With a stagger distance between 75m and 250m the junctions should normally be treated as two separate, signal-controlled T-junctions with local linking of the signals to favour the major flows of traffic through the junction:

- a. "straight ahead" on the major road (Arms A to C and C to A);
- b. the flow to and from the two staggered arms (Arms B to D and D to B);

or

- c. a combination of the above.

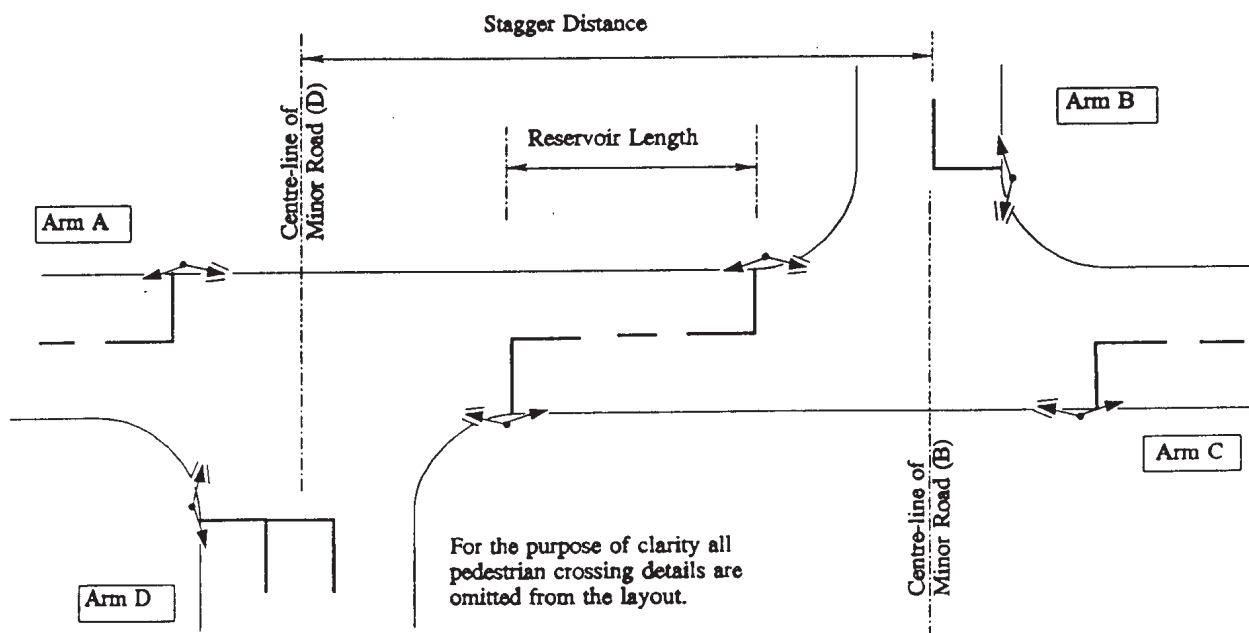

Figure 5/5: Stagger Distance and Reservoir Length

5.17 Where the stagger distance is below 75m the junction should normally be considered as a single signal-controlled staggered junction, provided there is sufficient reservoir length [See paragraph 5.18].

Reservoir Length

5.18 The reservoir length is the distance between the inner stop lines, as indicated in **Figure 5/5**. The available length for the reservoir is dependent upon the stagger distance and whether or not pedestrian crossing facilities are provided within the stagger distance.

5.19 As the stagger distance reduces below 75m it becomes more difficult to provide for the inner stop lines, pedestrian crossing facilities and the associated signals, where required. The shortest effective reservoir length is 15m. With a reservoir length below 15m it is recommended that the junction be treated as a signal-controlled crossroad with special account being taken of the longer clearance distances.

5.20 Staggered junctions may suffer from junction blocking due to a limited reservoir length between the two staggered arms.

Right/Left Stagers

5.21 Depending on the volumes and distribution of traffic, and the stagger distance, the inner stop-lines [marked "Y" on **Figure 5/6**] are of varying importance. With a stagger distance of 75m or greater, the inner stop-lines should be included to eliminate the very long clearance distances and extended intergreen periods which would otherwise be necessary.

5.22 Where a significant volume of pedestrian movement is anticipated the staggered junction may require pedestrian facilities at each stop-line as illustrated on Arms A, C and D of **Figure 5/6** (lower half). Where no pedestrian desire lines exist, and the stagger distance is not too great, a reduced number of pedestrian crossing facilities may be justified, as indicated on Arms B and C of **Figure 5/6** (upper half).

5.23 **Figure 5/6** illustrates an example of an urban right/left staggered junction, typical of a situation where the stagger distance is less than 75m, the reservoir length is greater than 15m and the presence of large goods vehicles in significant proportions is not expected. The following design features are incorporated into the example illustrated:

- a. two lane approach and departure on all arms;
- b. circular corner radii without tapers (no provision for large goods vehicles);
- c. inner stop-lines.

Left/Right Stagers

5.24 A left/right stagger will usually have difficult traffic conflicts which could have an adverse affect upon safety.

5.25 If such a junction with less than a 75m stagger is signalled using a 2-stage control (ie both the staggered arms run together), the major problem is conflict of traffic [marked as "X" - "X" on **Fig 5/7**] as the traffic emerging from one of the arms turns right across the path of vehicles turning right into the same arm. This can be particularly dangerous when drivers do not have intervisibility approaching the conflict point. Unless these movements are very low in volume and the length of stagger is small, it is recommended that 3-stage signalling be used with separate stages for each of the staggered approaches.

5.26 **Figure 5/7** illustrates an example of an urban left/right staggered signal-controlled junction, typical of a situation where the stagger distance is less than 75m, the reservoir length is greater than 15m and the presence of large goods vehicles in significant proportions is not expected. The following design features are incorporated in the example illustrated:

- a. two lane approach and departure on all arms;
- b. circular corner radii without tapers (no provision for large goods vehicles);
- c. inner stop lines.

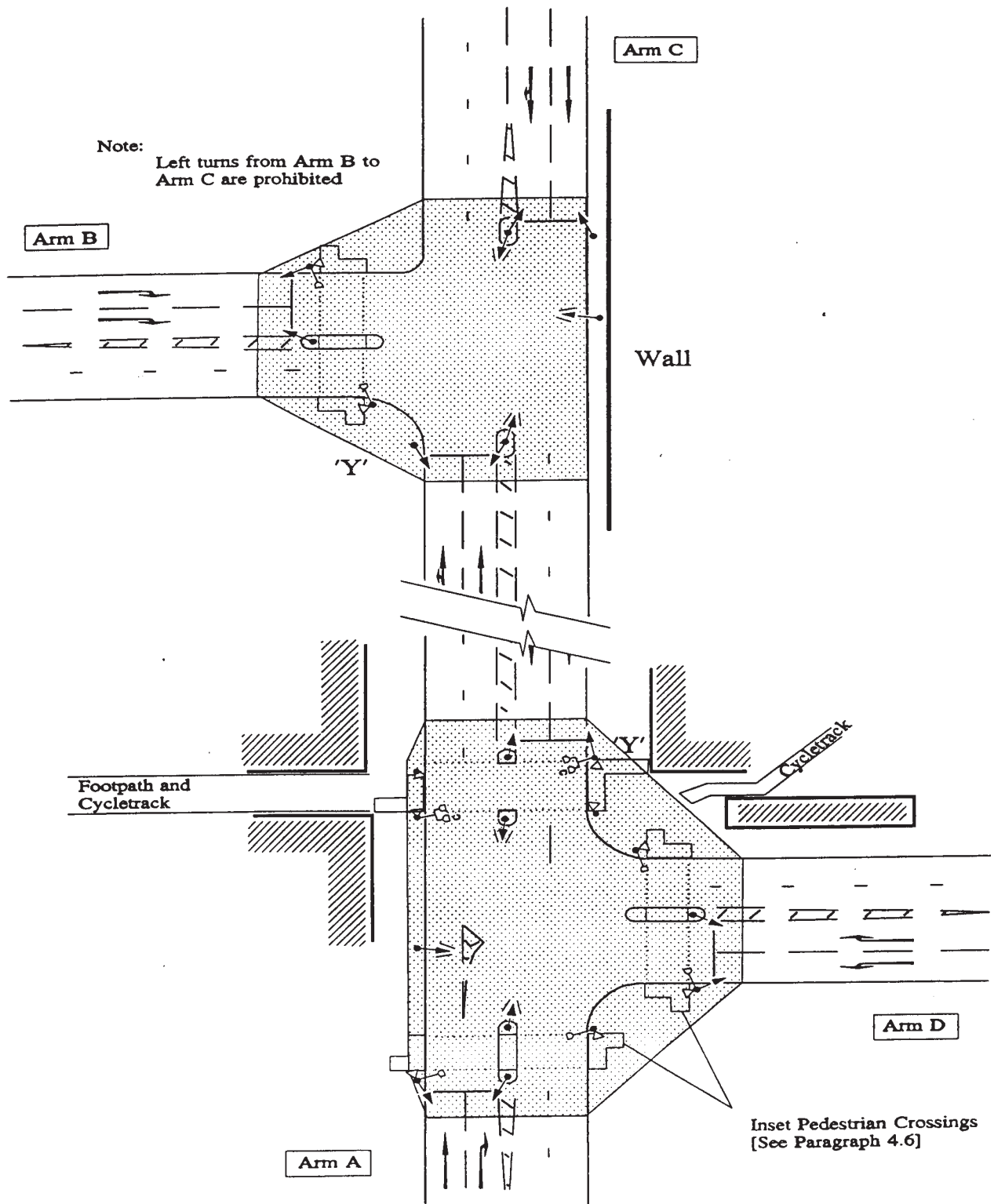

Figure 5/6: Example of a Right/Left Staggered Junction

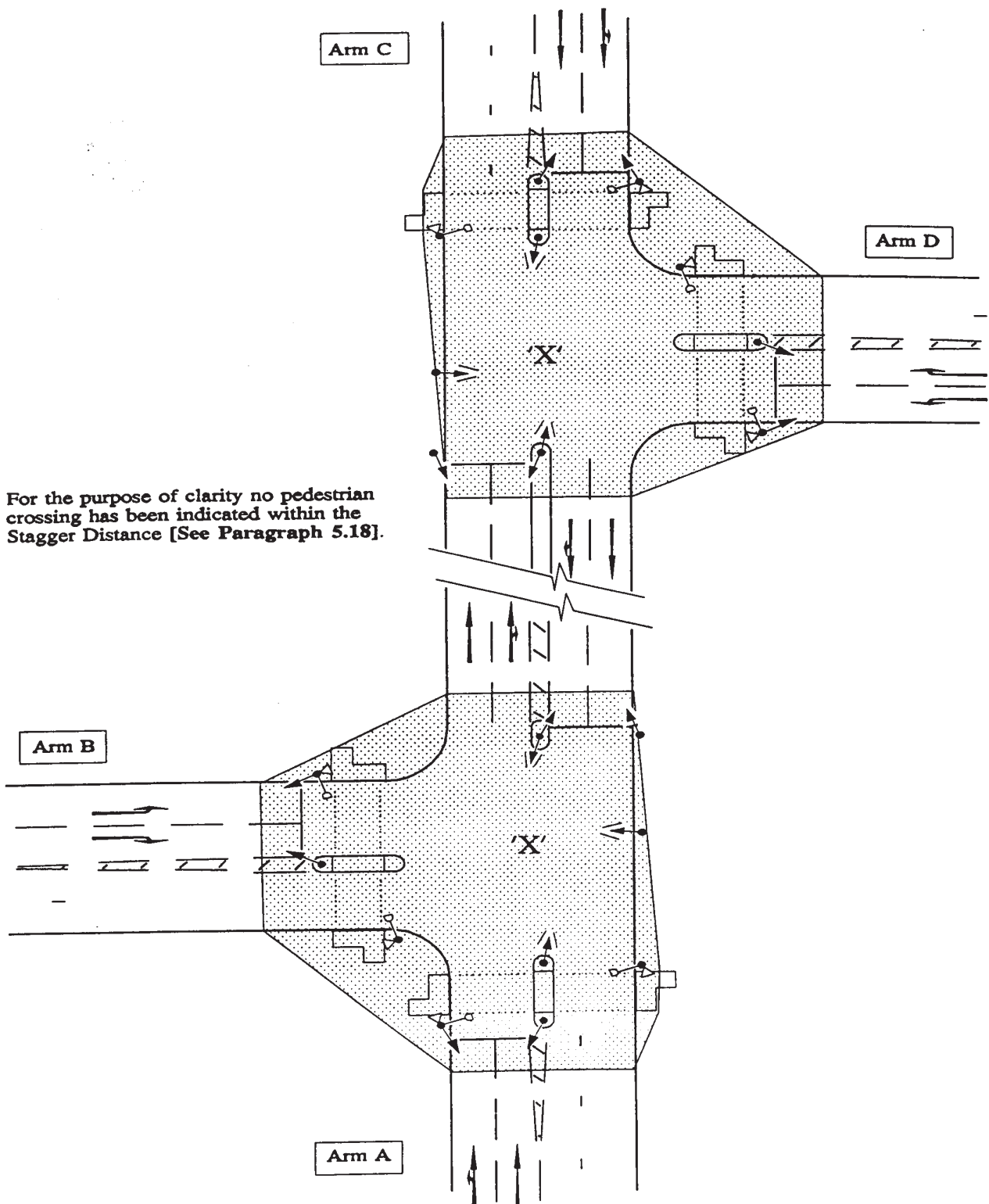

Figure 5/7: Example of a Left/Right Staggered Junction

Signal-Controlled Skew Junctions

5.27 The angle of intersection between the major and minor carriageways should preferably be 90°, although, intersection angles between 70° and 90° may be acceptable where physical constraints are significant. Where the roads intersect at angles other than 90° the major problems encountered are tight turning manoeuvres and locating secondary signals. Turning radii can be improved by the introduction of left turn slip lanes. It may be desirable to set stop-lines back by a significant distance to accommodate the junction corner radii, left turn slip lanes and to assist in locating secondary signals. **Figure 5/8** illustrates the terminology used to describe skew junctions and for the purpose of clarity no pedestrian facilities are indicated.

5.29 Problems associated with angles of intersection less than 70° are:

- a. priority may not be obvious to drivers;
- b. intervisibility within the junction intervisibility zone may be adversely affected;
- c. undesirable high speed turning movements may be possible on the obtuse angles of the junction;
- d. difficulty in locating secondary signals satisfactorily [See Paragraph 2.63].

5.28 Intersection angles below 70° shall be considered as departures from standards.

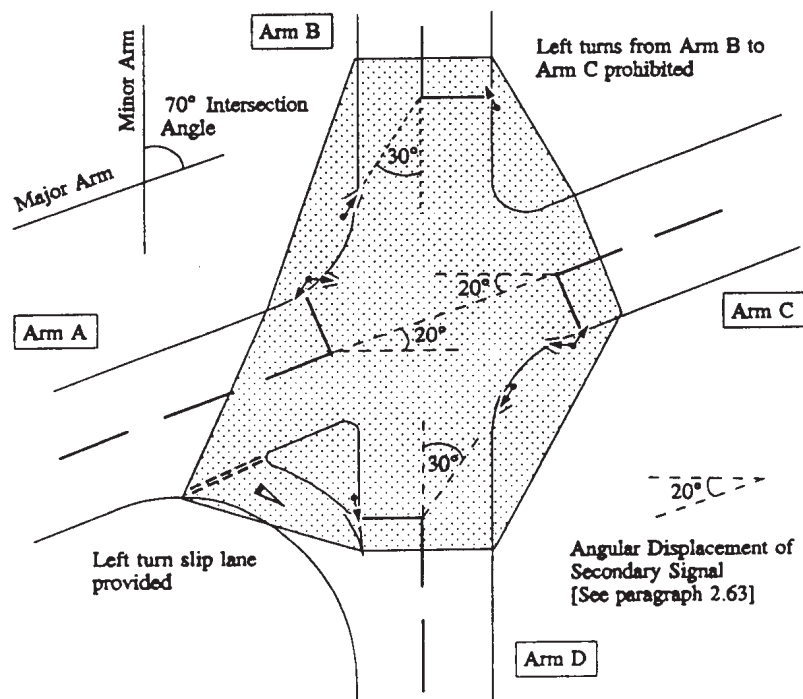

Figure 5/8: Example of a Signal-Controlled Skew Junction

5.30 **Figure 5/8** illustrates an example of an existing urban signal-controlled skew junction between two single carriageways intersecting at 70°, typical of a situation where available road space is restricted and the presence of large goods vehicles in significant proportions is not expected. The following specific design features are incorporated into the example:

- a. single lane approach and departure on all arms;
- b. circular corner radii without tapers (no provision for large goods vehicles);
- c. a simple left turn slip lane and priority junction (Arm D to A);
- d. left turn movements from Arm B to C are prohibited due to the tight corner radius.

Signal-Controlled Junctions On One-Way Roads

5.31 **Figure 5/9** illustrates an example of a signal-controlled junction between two one-way roads (Arms A and B) and a two way road (Arm C) incorporating a splitter island and pedestrian crossing facilities.

Signal-Controlled Junctions With More Than Four Arms

5.32 When signal-controlled junctions have more than 4 arms, efficient signalling is difficult to design. The banning of one or more right turns or directing traffic away from the junction will assist in alleviating these difficulties. It is not possible to give general guidance and each case should be treated according to the specific problems inherent in the layout.

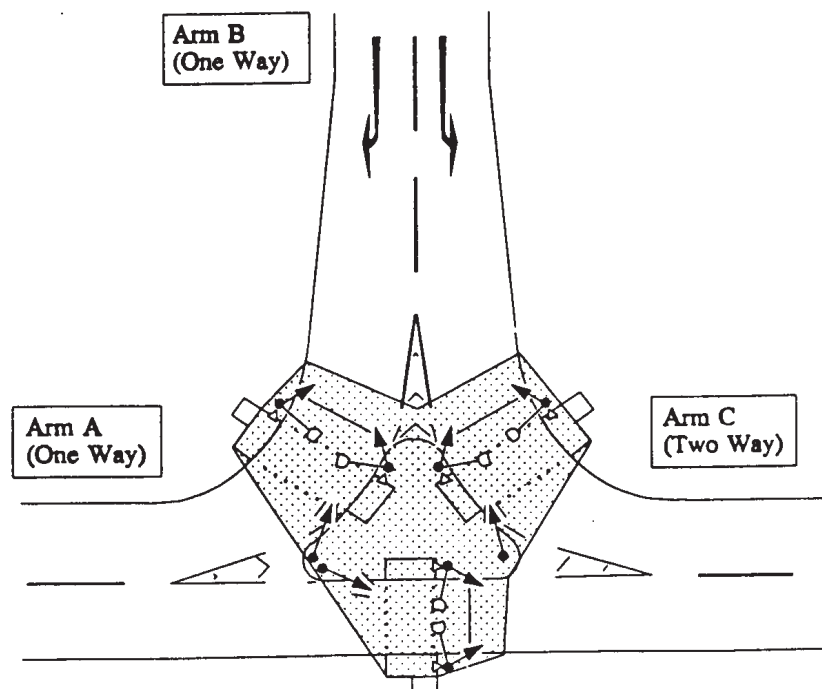

Figure 5/9: Example of a Signal-Controlled Junction On One-Way Roads

6. SIGNALISED ROUNDABOUTS

General

6.1 Guidance on the provision of traffic signals at roundabouts is contained in **Local Transport Notes (LTN)** identified in the **Department of Environment, Transport and the Regions (DETR)** publication list which discusses the specific traffic problems associated with roundabouts which may be resolved by the application of traffic signals, with or without the need for geometric changes. Where roundabouts require signals on most or all entries, computer programs are usually employed for modelling purposes.

6.2 By a combination of physical improvements, road markings [See **TA 78 (DMRB 6.2.3)**] and signalling it may be possible to increase capacity, provide better balance of queues, reduce speed and improve safety (particularly for cyclists). Lane control at signalised roundabouts may be improved by the effective use of route indications on the external and internal approaches to direct traffic to the appropriate exit arms, as illustrated in **Figure 6/1**.

6.3 Under normal priority control at each entry, roundabouts operate in a self-regulating manner. However, signalised roundabouts have signal control on one or more of the external approaches (entry arms) and may also have signal control on one or more internal approaches (circulatory carriageway). Signalised roundabouts may also operate in a self-regulating manner to a varying degree, depending upon a combination of the extent, method and duration of the signal control conditions and the size of the roundabout [See **Paragraphs 6.12 to 6.21**].

6.4 No two signalised roundabouts will be alike and, as a consequence general guidance only can be provided on the geometric design for various forms of signalised roundabouts.

Pedestrian Crossing Facilities

6.5 This chapter provides advice with regard to larger roundabouts located in rural areas where pedestrian movements are infrequent or non-existent. In urban locations, particular care should be taken to cater for pedestrians and advice concerning the type and location of facilities is contained in the **LTNs** identified in the **DETR** publication list. Where pedestrian usage is

frequent, pedestrian crossing facilities should be designed in accordance with the advice contained in **Chapter 4**.

6.6 The provision of traffic signals on entries to the roundabout also assists in separating the conflict between vehicular and pedestrian movements. When signal-controlled pedestrian crossing facilities are incorporated on the exit arms, designers should ensure that adequate storage length is provided to avoid traffic queuing back onto the circulatory carriageway.

Geometric Design Standards

6.7 This chapter provides guidance on the application of geometric design standards for signalised roundabouts.

6.8 The geometric design standards contained in **TD 16 (DMRB 6.2.3)** should be applied to external and internal approaches which operate in a self-regulating manner at any time (ie those approaches without signal control and those with part-time signal control). The standards contained in **TD 16 (DMRB 6.2.3)** should also be applied to those approaches with indirect signal control [See **Paragraph 6.16**].

6.9 The geometric design standards contained in Chapters 1 to 5 (inclusive) should be applied to external approaches which operate with direct [See **Paragraph 6.15**] full-time signal control. The standards should also be considered for those external approaches which operate with direct part-time signal control, however the standards contained in **TD 16 (DMRB 6.2.3)** take precedence under these circumstances.

6.10 For signalised roundabouts the junction intervisibility zone [See **Paragraphs 2.10 to 2.13**] on the circulatory carriageway should be measured to a point 2.5m beyond the secondary signal, as indicated in **Figure 6/1**.

6.11 The requirements for junction intervisibility [See **Paragraphs 2.14 to 2.18**] shall be applied to all internal and external approaches which operate under signal control at any time.

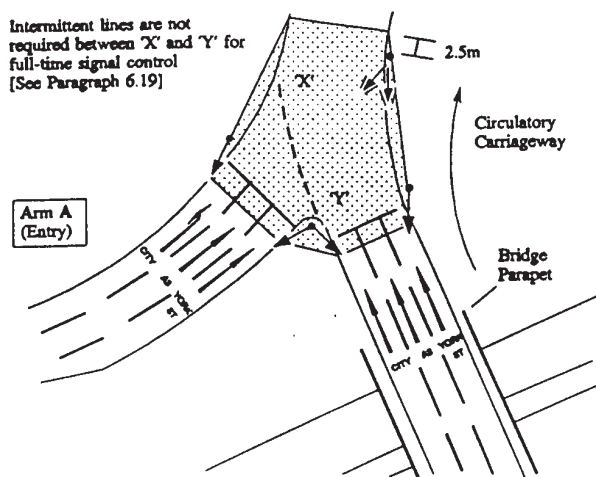

Figure 6/1: Junction Control Area

Size

6.12 The engineering problems posed in the design of a signalised roundabout are usually more exacting for a small roundabout than for a large roundabout. This is due to the physical constraints imposed on the internal link lengths between each signal-controlled approach, which affect the interaction between the individual approach signals.

Extent of Signal control

6.13 Fully controlled is the condition where signal control is provided on all internal and external approaches (ie the direct method of signal control).

6.14 Partial-control is the condition where one or more of the approaches remain under priority control. Partial-control can be used where traffic congestion does not occur on all external approaches.

Methods of Signal control

6.15 Direct signal control is the condition where the signals are situated on one or more of the external approaches and the internal approach immediately to the right of each signal-controlled entry. **Figure 6/2** illustrates an example of a large signalised roundabout with partial, direct signal control, where traffic flows on the minor roads (Arms B and C) are light and continue to operate in a self-regulating manner under normal priority control.

6.16 Indirect signal control is the condition where the signals are situated at such a distance away from the roundabout entry, that the entry continues to operate in a self-regulating manner under normal priority control. **Figure 6/3** illustrates an example of a signalised roundabout with indirect signal control on each entry arm.

6.17 Indirect signal control may be used where an entry arm with a very heavy traffic flow is preceded (ie is to the left of) an entry arm with a very light traffic flow. The heavy flow may often proceed virtually uninterrupted, possibly with high circulatory speeds. This causes an unbalanced traffic flow which adversely affects the capacity of the roundabout and can lead to excessive queue lengths (and substantial delays) to other external approaches which in turn may result in congestion at preceding junctions or on slip roads.

6.18 The installation of indirect signal control [See **Figure 6/3**] can be introduced to control entry flows on one or more approaches and can provide a gap in the circulatory traffic, to favour those entry arms which were previously subjected to excessive delays and queues. In this way the capacity of the entry arms can be balanced, however increases in vehicle gap distances may be detrimental to cyclists and pedestrians crossing the arms.

Duration of Signal control

6.19 Full-time control is the condition where signals are permanently operating. Under full-time signal control the give way road marking across any signalised entries to the roundabout should not be provided [See **Figure 6/1**].

6.20 Part-time control is the condition where signals are switched on at set times (generally peak periods) or under certain traffic conditions by queue detectors. When traffic flows are light the roundabout operates in a self-regulating manner under normal priority control.

6.21 The examples illustrated in **Figures 6/2** and **6/3** could both operate under full-time or part-time signal control.

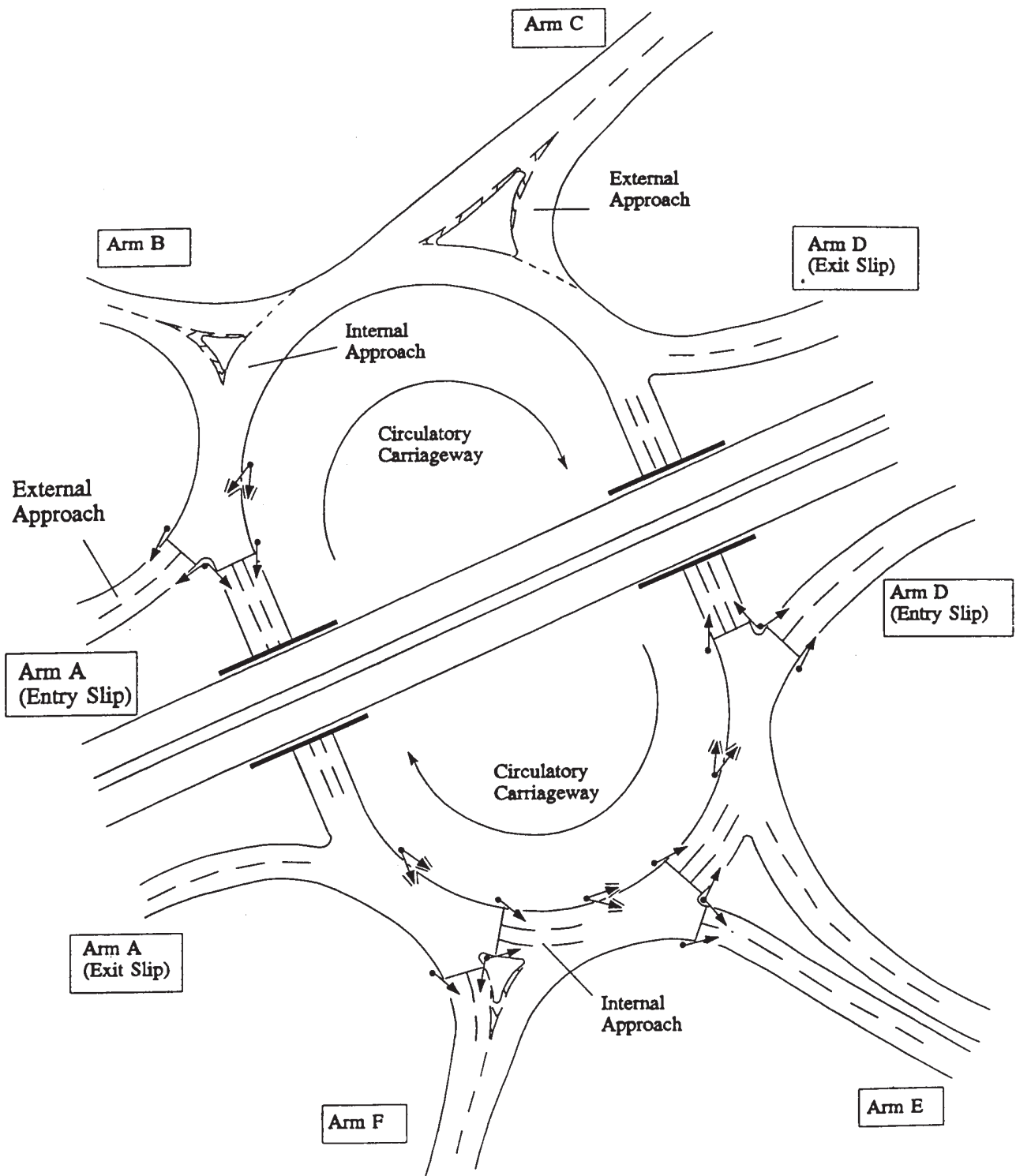

Figure 6/2: Example of Large Signalised Roundabout with Partial, Direct Signal Control

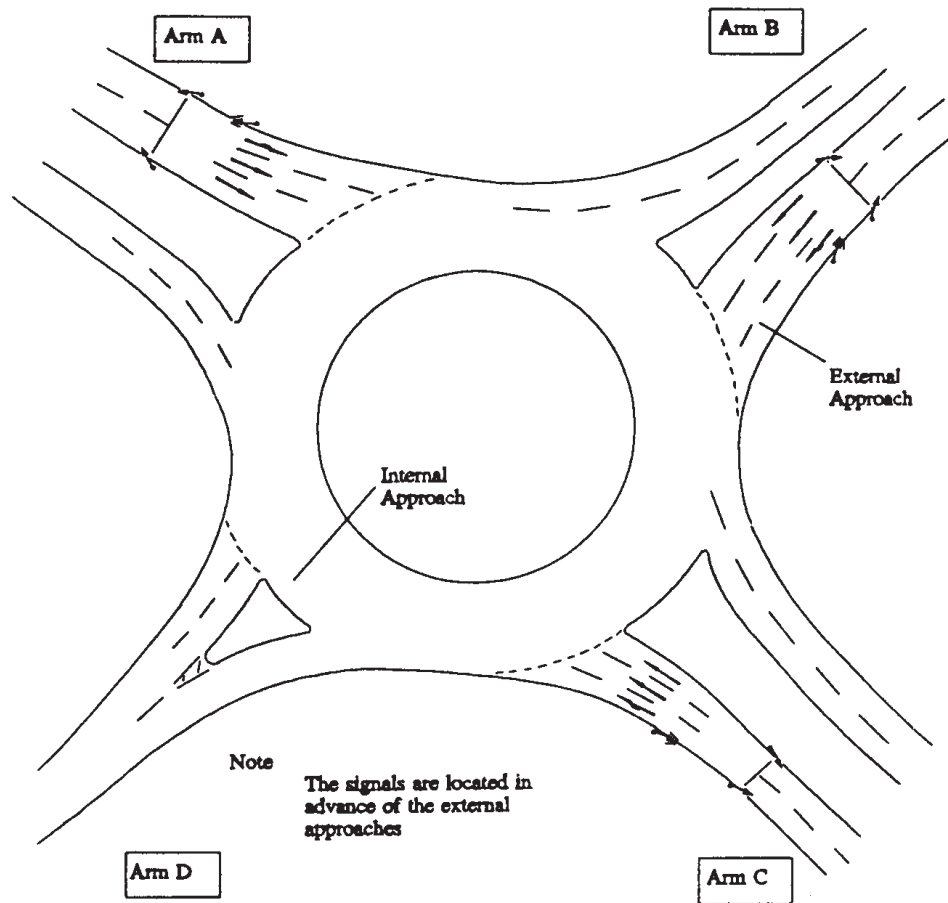

Figure 6/3: Signalised Roundabout with Indirect Signal Control

Geometric Modifications

6.22 Geometric modifications may be required to roundabouts in order to:

- increase capacity on external approaches;
- increase capacity on the circulatory carriageway;
- accommodate queues at internal stop lines on the circulatory carriageway;
- improve forward visibility and intervisibility in the junction intervisibility zone;
- provide alignment improvements and lane control measures;
- provide specific measures for pedestrians, cyclists and buses.

6.23 These modifications may take the form of:

- additional nearside or offside approach lanes;
- additional internal approach lanes within the circulatory carriageway;
- increasing the size of splitter islands in order to achieve longer internal approaches;
- segregated facilities or signalled crossing facilities.

Offside Approach Lane

6.24 The provision of an additional offside external approach lane, as illustrated in **Figure 6/4**, is appropriate where:

- sufficient space is available on the offside, within the central median;
- a nearside approach lane would result in inadequate internal queuing capacity on the internal approach to the left;
- it does not significantly reduce the queuing capacity on the internal approach to the right.

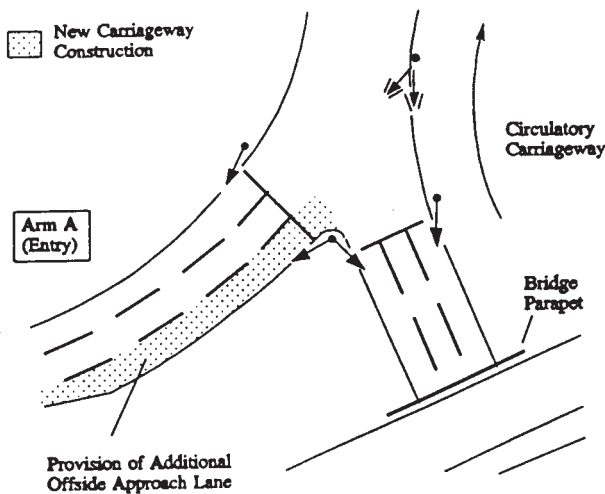

Figure 6/4: Provision of Additional Offside Approach Lane

Nearside Approach Lane

6.25 The provision of an additional nearside external approach lane as illustrated in **Figure 6/5** is appropriate where:

- sufficient space is available on the nearside;
- an offside external approach lane would result in inadequate queuing capacity on the internal approach to the right;
- it does not significantly reduce the queuing capacity on the internal approach to the left.

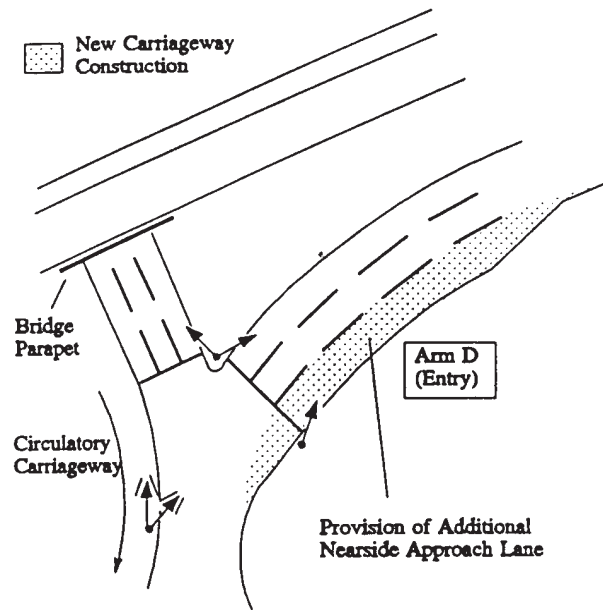

Figure 6/5: Provision of Additional Nearside Approach Lane

Internal Approach Lanes

6.26 In **Figure 6/2** the internal queuing capacity on the circulatory carriageway to the right of Arm E is limited by the width of the central reserve on the dual carriageway approach. Similarly, to the right of Arm F the internal queuing capacity is severely limited by the size of the deflection island. Internal approach lanes less than 15m in length may result in the blockage of the exit arm, particularly where Large Goods Vehicles are present and the effect of these internal queues should be considered when assessing the performance of the roundabout.

6.27 Under full-time signal control the capacity on the internal approaches to Arms E and F could be improved by geometric modifications [See **Figure 6/6**] to these external approaches by significantly reducing the entry radii. Under part-time signal control however the scope for geometric modifications is reduced due to the requirements for the design to be in accordance with **TD 16 (DMRB 6.2.3)**.

6.28 **Figure 6/6** illustrates how the queuing capacity on the internal approach to the right of Arm F may be increased by increasing the size of the splitter island and realigning the external approach arm.

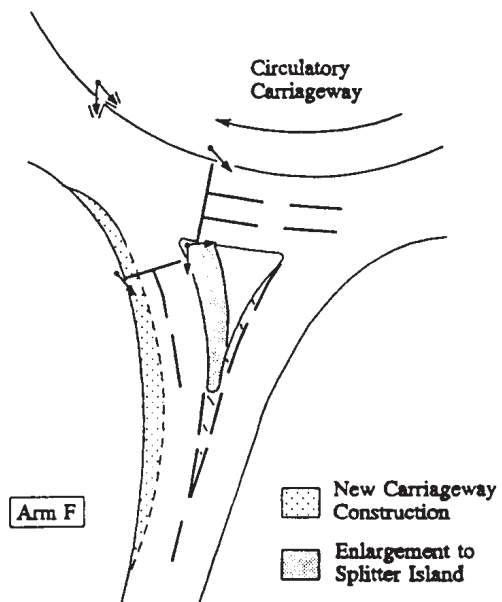

Figure 6/6: Improvement to Internal Queuing Lanes

7. REFERENCES

1. **DESIGN MANUAL FOR ROADS AND BRIDGES (DMRB):**
 - a. Design Manual for Roads and Bridges, Volume 5 Assessment and Preparation of Road Schemes, Section 1 Assessment of Road Schemes, TA 22/81 Vehicle Speed Measurements on All Purpose Roads.
 - b. Design Manual for Roads and Bridges, Volume 5 Assessment and Preparation of Road Schemes, Section 1 Assessment of Road Schemes, TA 30/82 Choice Between Options for Trunk Road Schemes. (*Scottish Addendum applicable for use in Scotland*)
 - c. Design Manual for Roads and Bridges, Volume 6 Road Geometry, Section 1 Links, TD 9/93 Highway Link Design.
 - d. Design Manual for Roads and Bridges, Volume 6 Road Geometry, Section 2 Junctions, TD 16/93 Geometric Design of Roundabouts.
 - e. Design Manual for Roads and Bridges, Volume 6 Road Geometry, Section 2 Junctions, TA 78/97 Design of Road Markings at Roundabouts.
 - f. Design Manual for Roads and Bridges, Volume 6 Road Geometry, Section 2 Junctions TD 42/95 Geometric Design of Major/Minor Priority Junctions.
 - g. Design Manual for Roads and Bridges, Volume 6 Road Geometry, Section 3 Highway Features, TA 57/87 Roadside Features. (*Scottish Addendum applicable for use in Scotland, Northern Ireland Addendum applicable for use in Northern Ireland*)
 - h. Design Manual for Roads and Bridges, Volume 7 Pavement Design and Maintenance, Section 3 Pavement Maintenance Assessment, HD 28/94 Skidding Resistance.
 - i. Design Manual for Roads and Bridges, Volume 8 Traffic Signs and Lighting, Section 1 Traffic Signals and Control Equipment, TD 35/91 All Purpose Trunk Roads - MOVA System of Traffic Control at Signals.
 - j. Design Manual for Roads and Bridges, Volume 8 Traffic Signs and Lighting, Section 1 Traffic Signals and Control Equipment, TA 12/81 Traffic Signals on High Speed Roads. (*Northern Ireland Addendum applicable for use in Northern Ireland*)
 - k. Design Manual for Roads and Bridges, Volume 8 Traffic Signs and Lighting, Section 1 Traffic Signals and Control Equipment, TA 82/99 The Installation of Traffic Signals and Associated Control Equipment. (*For incorporation of LTN 1/98 into DMRB*)
 - l. Design Manual for Roads and Bridges, Volume 8 Traffic Signs and Lighting, Section 1 Traffic Signals and Control Equipment, TA 15/81 Pedestrian Facilities at Traffic Signal Installations. (*Northern Ireland Addendum applicable for use in Northern Ireland*)
 - m. Design Manual for Roads and Bridges, Volume 8 Traffic Signs and Lighting, Section 1 Traffic Signals and Control Equipment, TA 16/81 General Principles for Control by Traffic Signals. (*Northern Ireland Addendum applicable for use in Northern Ireland*)
 - n. Design Manual for Roads and Bridges, Volume 8 Traffic Signs and Lighting, Section 1 Traffic Signals and Control Equipment, TD 7/80 Type Approval of Traffic Control Equipment. (*Not applicable for use in Northern Ireland*)
 - o. Design Manual for Roads and Bridges, Volume 8 Traffic Signs and Lighting, Section 1 Traffic Signals and Control Equipment, SH 6/73 Criteria for Traffic Light Signals at Junctions. (*For use in Scotland only*)
 - p. Design Manual for Roads and Bridges, Volume 8 Traffic Signs and Lighting, Section 2 Traffic Signs and Road Markings, TA 8/80 Carriageway Markings. Markings for Right Turning Movements at Cross Road Junctions. (*Northern Ireland Addendum applicable for use in Northern Ireland*)

- q. Design Manual for Roads and Bridges, Volume 8 Traffic Signs and Lighting, Section 3 Lighting, TD 30/87 The Design of Road Lighting for All Purpose Trunk Roads. (*Scottish Addendum applicable for use in Scotland, Northern Ireland Addendum applicable for use in Northern Ireland*)
- r. Design Manual for Roads and Bridges, Volume 8 Traffic Signs and Lighting, Section 5 Pedestrian Crossings, TA 68/96 The Assessment and Design of Pedestrian Crossings Local Transport Notes 1/95 and 2/95.
- s. Design Manual for Roads and Bridges, Volume 10 Environmental Design, Section 1 The Good Roads Guide - New Roads.
- t. Design Manual for Roads and Bridges, Volume 10 Environmental Design, Section 3 The Good Roads Guide - Improving Existing Roads.

2. TRAFFIC SIGNS REGULATIONS

- a. SI 1994 No 1519 - The Traffic Signs Regulations and General Directions 1994: HMSO.
- b. Traffic Signs Manual: HMSO
- c. Traffic Signs Regulations (Northern Ireland) 1997: HMSO

3. DEPARTMENT OF THE ENVIRONMENT TRANSPORT AND THE REGIONS

- a. TMT & CLT Divisions Publication List - These 2 Divisions are responsible for the development of policy on traffic control and management issues, including:
 - Cycling;
 - Traffic Calming;
 - Pedestrianisation;
 - Traffic Signs;
 - Bus Priority Systems;
 - Parking.

4. MOBILITY UNIT CIRCULARS

- a. Guidance on the use of Tactile Paving Surfaces.

5. MISCELLANEOUS

- a. Code of Practice for Traffic Control and Information Systems. (*to be published 1998*)
- b. Road vehicle (Construction and Use) Regulations 1986.
- c. RTN 4: HM Railway Inspectorate Technical Note On The Highway and Vehicle Engineering aspects of Street-Running Light Rapid Transit Systems (currently in Draft).
- d. TR 0141C Specification for Microprocessor Based Traffic Signal Controller.

8. ENQUIRIES

All technical enquiries or comments on this Standard should be sent in writing as appropriate to:

Chief Highway Engineer
The Highways Agency
123 Buckingham Palace Road
London
SW1W 9HA

G CLARKE
Chief Highway Engineer

Chief Road Engineer
Scottish Executive
Victoria Quay
Edinburgh
EH6 6QQ

J HOWISON
Chief Road Engineer

Chief Highway Engineer
Transport Directorate
Welsh Assembly Government
Llywodraeth Cynulliad Cymru
Crown Buildings
Cardiff
CF10 3NQ

M J A PARKER
Chief Highway Engineer
Transport Directorate

Director of Engineering
The Department for Regional Development
Roads Service
Clarence Court
10-18 Adelaide Street
Belfast BT2 8GB

G W ALLISTER
Director of Engineering

ANNEX 1 - TERMS AND DEFINITIONS USED IN TRAFFIC SIGNAL CONTROL

General

A1.1 The general principles of control by traffic signals are contained in **TA 16 (DMRB 8.1.1)** and definitions relating to signal control are given in **TR 0141B**. **Figure A1/1** indicates a T-junction layout used to illustrate the following terminology which is more fully described in those documents:

Phase

The sequence of conditions applied to one or more streams of vehicular traffic or pedestrian traffic which always receive identical signal light indications [See **Figure A1/1**].

Stage

A stage may be considered as starting at the point at which all phases that will have right-of-way during the stage have been set to green, and all phases terminating have been set to red. The stage may be considered to end at the point at which the first phase loses right of way [See **Figure A1/1**].

Cycle

One complete sequence of the operation of the traffic signals.

Intergreen Period

Period between the end of the green signal giving right of way for one phase, and the beginning of the green signal giving right of way for the next phase.

A1.2 The following terms are also described in **TR 0141B**:

Interstage Period

The period between the end of one stage and the start of the next stage [See **Figure A1/1**].

Early Cut-Off

A condition in which one or more traffic streams, that were running during the preceding stage, are stopped whilst one or more other traffic streams are allowed to continue moving.

Late Release

A condition in which one or more traffic streams are permitted to move before the release of other traffic streams which are permitted to run with them during the subsequent stage.

Primary and Secondary Signals

A1.3 Primary and Secondary Signals are defined in **Traffic Signs and General Directions 1994, Traffic Signs Regulations (Northern Ireland) 1997 (TSR[NI])** and to illustrate the terminology, **Figure A1/1** indicates typical locations on a simple T-junction:

Primary Signal

Light signals erected near the carriageway of a road and sited near one or both ends of the stop line. There must be at least one primary signal associated with each stop-line. An additional signal normally erected near the carriageway just beyond the stop line on the offside lane is termed a duplicate primary. The use of duplicate primary signals is recommended on all high speed approaches.

Secondary Signal

Light signals erected near the carriageway facing the traffic approaching from the direction of the primary signals but sited beyond those signals. The information given by a secondary signal must be the same as that given by the primary signal with which it is associated, but additional information compatible with that of the primary may also be given.

Closely-associated Secondary Signal

In special circumstances the secondary signal may be located just beyond the stop line and this is termed a **closely-associated secondary signal**.

Pedestrian Control Signals

A1.4 Details of the equipment relevant to pedestrian facilities are contained in **TA 15 (DMRB 8.1.1)** and **Figures 4/2** and **4/3** illustrate examples of the equipment:

Pedestrian Signals

Pedestrian signals to Diagram 4002 of the **Traffic Signs and General Directions 1994, Traffic Signs Regulations (Northern Ireland) 1997 (TSR[NI])**.

Pedestrian Push Button Units

Pedestrian push button units to Diagram 4003 of the **Traffic Signs and General Directions 1994, Traffic Signs Regulations (Northern Ireland) 1997 (TSR[NI])**.

Pedestrian Crossing Studs and Marks

Pedestrian crossing studs and marks to Diagram 1055 of the Traffic Signs Regulations and General Directions. Studs may present a hazard to motor cyclists and cyclists and the use of white roadmarkings may be considered in preference to studs.

Design Speed and Speed Limits

A1.5 **Table A1/1** provides a direct conversion from mph to kph for the permitted speed restrictions, designers should choose an appropriate higher design speed so as to permit a small margin for speeds in excess of the speed limit.

MPH	KPH
20	32.19
30	48.28
40	64.37
50	80.47
60	96.56

Table A1/1: Speed Conversion

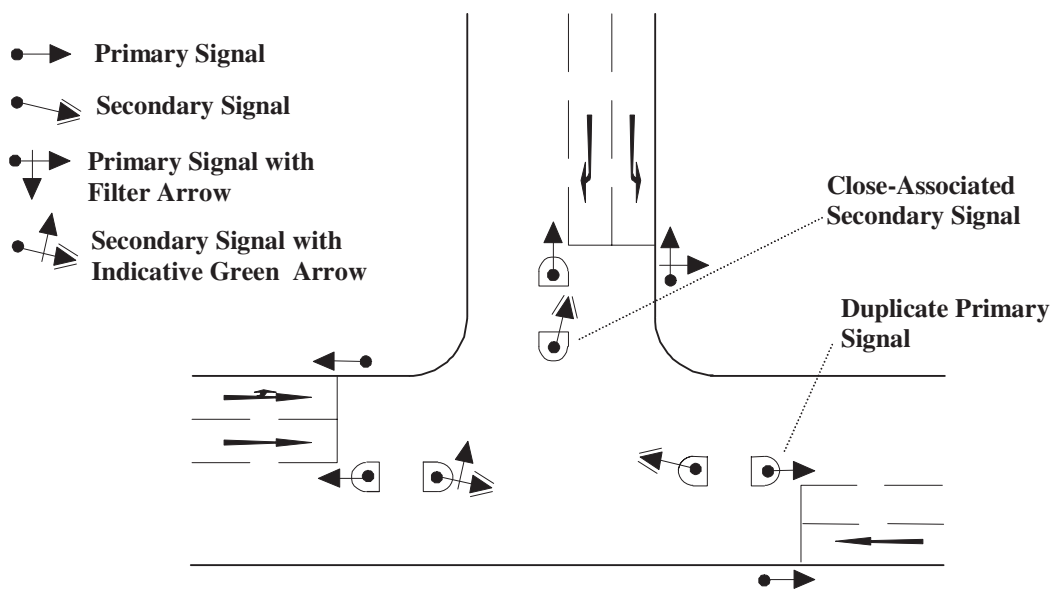

PHASE DIAGRAM

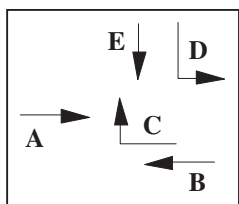

STAGE DIAGRAMS

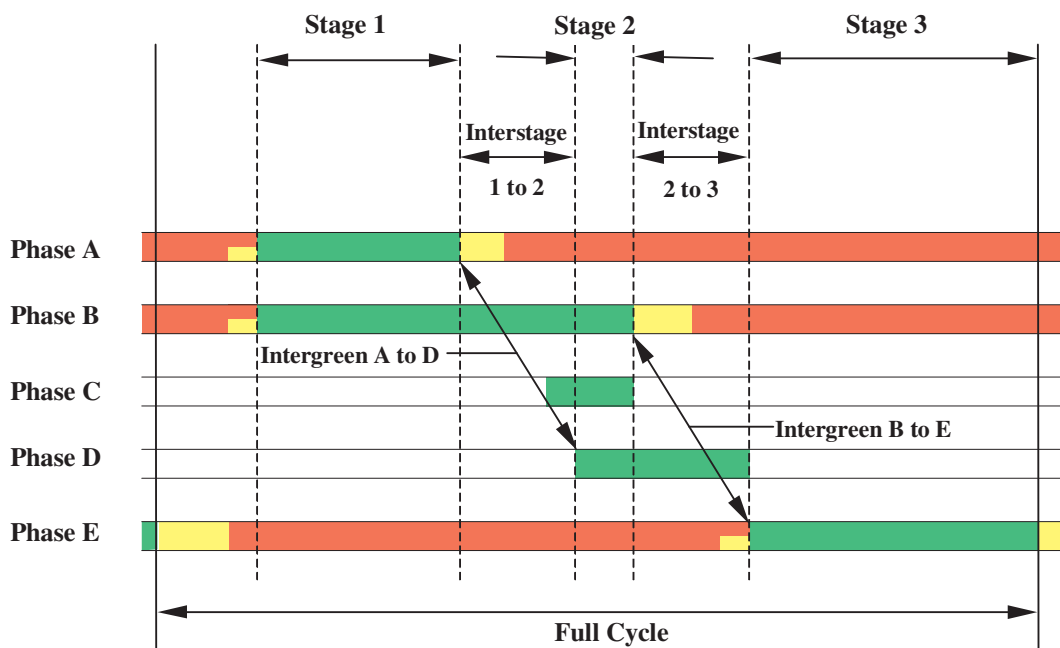
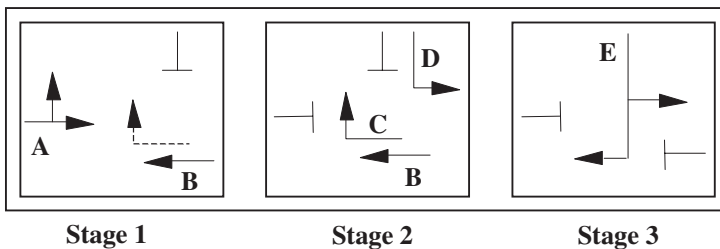

Figure A1/1: Definitions of Signal Control Terminology